



Section D Structural Design

Logicwall® Structural Design, Design for Earth Quake Actions, Non-Ductile Walling, Limited Ductile Walling, Wall Details, Core Filling of Walls

Contents

Definition of Terms Used in this Section.	4
D1. Structural Design	5
Introduction	5
Wall Properties	6
Fire Performance	6
FRP Insulation	7
Flexural Capacity	7
Lintels	7
Reinforcement Requirements	8
Minimum Reinforcement	8
Reinforcement Detailing Constraints	8
D2. LOGICWALL® Design For Earthquake Actions	9
D3. Non Ductile Wall Design	9
Axial Capacity	9
D3.1. LOGICWALL® LW120	10
LW120 Structural Capacities	10
D3.2. LOGICWALL® LW150	12
LW150 Structural Capacities	12
D3.3. LOGICWALL® LW162	14
LW162 Structural Capacities	14
D3.4. LOGICWALL® LW200 & LW200D	16
LW200D Structural Capacities	16
D3.5. LOGICWALL® LW262D	19
LW262D Structural Capacities	19
D4. Non-Ductile Wall Detailing	22
Junctions.	22
Standard wall junctions	22
Fig D1: Cross Junction	23
Fig D2: AFS Open Corner Capping	23
Fig D4: Standard Hook Bars	23
Fig D5: Angle Junction	23
Fig D3: T Junction Capping	23
Fig D6: Cross Junction	24
Fig D7: AFS Open Corner Capping	24
Fig D8: T Wall Junction Capping	24
Special junctions (where specified by the engineer)	25
Fig D9: Cross Junction	25
Fig D10: AFS Open Corner Capping	25
Fig D12: Standard U Bars	25
Fig D11: T Junction Capping	25
Prefabricated Corners	26
Fig D13: Standard L-Bar Factory Installed	26

Fig D15: Standard L Bar	26
Fig D14: Standard U-Bar Factory Installed	26
Non-Ductile Blade Walls/Columns27
Joints.27
Sheet Surface Joint27
Fig D18: Logicwall® Sheet Surface Joint	27
Movement Joints28
Fig D19: logicwall® Movement joint	28
Fig D20: Logicwall® Corner Joint	28
Fig D21: Logicwall® T joint	28
Construction Joint29
Fig D22: Logicwall® Sheet Surface Joint	29
D5. Limited Ductile Wall Design	30
Limited Ductile Design30
Fig D23: Sample Moment Interaction	30
Limited Ductile Design Examples31
D5.1. Limited Ductile Wall Detailing	33
Boundary Elements33
Reinforcement.33
Fig D24: AFS Standard U-Bar Detail	33
Fig D25: AFS Standard Boundary Element	33
Fig D26: AFS Limited Ductile Core Wall Detailing	34
AFS Limited Ductile Wall Horizontal Reinforcement Wall Laps	34
Fig D27: 14.6.7(D) Horizontal Wall Bar Lap Detail	34
Blade Columns35
Fig D28: LOGICWALL® Blade Column	35
Junctions.35
Fig D29: Corner Type 1	35
Fig D30: T junction	35
Movement Joints36
Fig D32: logicwall® Movement joint	36
Construction Joint37
Fig D33: Logicwall® Sheet Surface Joint	37
Wall Junctions Joints37
Fig D34: Logicwall® Corner Joint	37
Fig D35: Logicwall® T joint	37
D6. CORE FILLING OF WALLS	38
Introduction38
Concrete Pour Limitations38
Additional Equipment Required for Concrete Pour38
AFS and Natspec39

Definition of Terms Used in this Section

t_w	Effective structural concrete wall width
$t_{w,\text{fire}}$	Effective wall width for fire
S_{web}	Web spacing
S_{punch}	Vertical punch spacing
A_c	Percentage of web opening
Align	Allowance for on-site mis-alignment of web openings
N_{layers}	Number of Reinforcement layers
d_h	Distance to centre of horizontal bar from the Logicwall® concrete face
$f'_{c,\text{max}}$	Maximum concrete strength
f_y	Steel yield stress
Bar Max	Max reinforcement bar size
e	The eccentricity of the load measured at right angle to the plane of the wall
H_{wu}	Unsupported wall height
H_{we}	Effective wall height

D1. Structural Design

Disclaimer: This section of the AFS Logicwall® Design Guide is intended only by AFS to represent good building practice in achieving suitable internal design of AFS Logicwall®. This section is not intended in any way by AFS to represent all relevant information required on a project. It is the responsibility of those using AFS Logicwall®, including but not limited to builders, designers, consultants and engineers, to ensure that AFS Logicwall® is suitable for use on a project in relation to internal design. All diagram, plans and illustrations used in this section including any reinforcement shown are included for indicative and diagrammatic purposes only. It remains the responsibility of those using AFS Logicwall® to ensure that reference is made to the structural engineer's details for all diagrammatic and reinforcement requirements.

Introduction

AFS Logicwall® is a CodeMark certified permanent formwork for load bearing insitu concrete walls. Its lightweight, sandwich panels are created by bonding durable compressed fibre cement sheets to galvanised steel stud frames. This section of the Logicwall® Design Guide provides guidelines for the structural design of walls constructed using Logicwall® and are designed as reinforced concrete walls in accordance with the AS3600 (2018) Concrete Structures Code.

The following areas of structural design are discussed in this section:

- Non ductile wall design
- Limited ductile wall design

Non ductile and limited ductile wall design of Logicwall® shall be carried out in accordance with AS3600 (2018)

Wall Properties

TABLE D4: Wall Properties

Wall Type	Stud Spacing	t_w	t_{total}	D_{punch}	A.stud	I_{xx}	$A_c\%$	$f_{y,stud}$	A_{fl}	Overall R.Wall Factors	
	(mm)	(mm)	(mm)	(mm)	(mm)	(mm 4×10^3)		MPa	mm 2 /m	μ	K_{co}
LW120	146	108	120	70	63.69	164.2	47.1%	300	502	0.741	0.235
LW150	146	136	148	100	68.09	276.5	52.3%	300	502	0.756	0.260
LW162	146	150	162	100	75.79	358.4	47.2%	300	502	0.742	0.236
LW200	146	188	200	134	77.99	602.9	50.0%	300	502	0.750	0.250
LW200D	146	188	200	134	77.99	602.9	50.0%	300	502	0.750	0.250
LW262D	146	250	262	211	115.39	1303.5	49.5%	300	502	0.750	0.250

Fire Performance

TABLE D1: FRL by CSIRO Fire Test

Type	t_{fire}	$H_w max$	$N^* max$	FRL
	(mm)	(mm)	(kN/m)	(Ade/Int/Ins)
LW120	120	3000	233	240/240/180*
LW150	145	3000	233	240/240/180**
LW162	160	3000	233	240/240/240***
LW200D	200	3000	233	240/240/240***
LW262D	260	3000	233	240/240/240***

*FRL Determined by CSIRO Fire Test Number FS4259/3484 with minimum reinforcement

**FRL determined by CSIRO Fire Test Number FS3637/2585 with minimum reinforcement with FRL period [240/240/236].

***Based on AFS150 FRL test results and allowing for additional concrete thickness. Refer to Report No. FCO-3084B by CSIRO

FRL by AS3600-2018

Where design is outside the limits given in the above table FRL shall be determined in accordance with AS 3600-2018.

Where calculating structural capacity for a fire load the area of the exposed stud flange is to be excluded

TABLE D2: AS3600 FRL (Ade/Int/Ins#2) – Exposed 1 Side

	Cl 5.8.1#1	30/30/180	60/60/180	90/90/180	120/120/180	180/180/240	240/240/240
Wall	t_{fire}	$N^*f/\phi N_u$	$N^*f/\phi N_u$	$N^*f/\phi N_u$	$N^*f/\phi N_u$	$N^*f/\phi N_u$	$N^*f/\phi N_u$
LW120	120	0.70	0.53	0.35	0.18		
LW150	145	0.70	0.70	0.70	0.25		
LW162	160	0.70	0.70	0.70	0.70		
LW200	200	0.70	0.70	0.70	0.70	0.58	
LW262D	260	0.70	0.70	0.70	0.70	0.70	0.62

TABLE D3: AS3600 FRL (Ade/Int/Ins#2) – Exposed 2 Side

	Cl 5.8.1#1	30/30/180	60/60/180	90/90/180	120/120/180	180/180/240	240/240/240
Wall	t_{fire}	$N^*f/\phi N_u$	$N^*f/\phi N_u$	$N^*f/\phi N_u$	$N^*f/\phi N_u$	$N^*f/\phi N_u$	$N^*f/\phi N_u$
LW120	120	0.70	0.35				
LW150	145	0.70	0.70	0.43	0.11		
LW162	160	0.70	0.70	0.61	0.35		
LW200	200	0.70	0.70	0.70	0.64	0.35	0.06
LW262D	260	0.70	0.70	0.70	0.70	0.65	0.40

#1 Cl 5.8.1: $t_{\text{fire}} = t_w + t_{\text{FCsheet}}$ rounded up to the nearest 5mm

#2 FRP Based on CSIRO Fire Tests

FRP Insulation

FRP for Insulation in the previous tables is determined by CSIRO Testing for walls less than LW200 and in accordance with AS3600-2018 Table 5.7.1 for walls greater than LW200.

Electrical boxes, chases or other hollows in walls must maintain a minimum separation and concrete thickness as given in the AS3600-2018 FRP Insulation Table below.

TABLE D5: Fire Resistance Periods (FRPs) for walls for insulation

FRP for installation (min)	Effective thickness (mm)
30	60
60	80
90	160
120	120
180	150
240	175

Flexural Capacity

The flexural strength of Logicwall® s obtained by the stud flanges acting as reinforcement therefore from classic beam theory ignoring axial forces and any vertical reinforcement:

$$\phi M_u = f_{\text{stud}} t_w A_{\text{flange}} \left(1 - 0.6 \frac{A_{\text{flange}}}{b t_w} \frac{f_{\text{stud}}}{f'_c} \right)$$

Where:

$\phi = 0.8$ strength reduction factor

M_u ultimate flexural capacity

f_{stud} yield strength of vertical studs

A_{flange} area of stud flange

f'_c characteristic compressive strength of concrete

Since the stud flanges are potentially exposed to fire they can only be used for Wind Loads in accordance with AS/NZS1170.2.

If flexural capacity other than Wind Loads is required then the wall may be reinforced and designed as a normal reinforced concrete wall.

Lintels

Lintel tables have been prepared based on a wall with minimum reinforcement for bending and shear capacity. If additional capacity is required, extra reinforcement can be designed and detailed by the engineer.

Reinforcement Requirements

The individual cells within AFS Logicwall® allow horizontal shrinkage and thermal movements in the concrete with the internal studs acting as crack inducers. This allows AFS Logicwall® to provide crack control without additional reinforcement. The vertical studs can be considered as non fire-rated vertical reinforcement.

For fire-rated reinforced walls to AS3600-2018 Cl11.7.1 use minimum vertical reinforcement ratio (ρ_w)

of 0.0015 or the value required by structural analysis.

Due to the presence of the steel studs in AFS Logicwall® steel congestion should be avoided to facilitate adequate compaction of concrete. As a guide steel ratios in excess of 0.02 in a single layer should not be used unless the amount and disposition of the reinforcement will not prevent the proper placement and compaction of the concrete at splices and at junctions of members.

Minimum Reinforcement

For walls required that have tensile forces from any load combination AS3600-2018 11.7 Minimum reinforcement shall apply.

Examples of such walls are:

- Walls resisting lateral loads
- Walls acting as deep beams
- Walls with load combinations of bending and compression producing tension stress.
- Where reinforced AFS Logicwall® walls do not require a high degree of crack control for tensile forces we recommend a minimum reinforcement spacing of 400mm.

- Horizontal reinforcement may be reduced to zero for walls supporting vertical loads only where the wall is designed for one way buckling and the studs act as crack inducers for removing restraint against horizontal shrinkage or thermal movement.

Notes: AS3600 does not recognise the use of plain concrete in wall elements, though some International standards offer guidance in this area. Use of AFS Logicwall® walls unreinforced will require reference to other codes such as ACI 318 and BS8110.1 where it can be shown that no tensile forces result from any load combination of bending and compression.

TABLE D6: Minimum Reinforcement for Reinforced Walls ($\rho = A_{st}/A_{conc}$)

Location	Vertical (ρ)	Horizontal (ρ)
Internal (A1, A2)	0.0025 (0.0015 Cl.11.7.1(a))	0.0015
External (B1, B2)	0.0025 (0.0015 Cl.11.7.1(a))	0.0025
Limited Ductile	0.0025	0.0025
Deep Beam	AS3600 Sect 12	AS3600 Sect 12

Steel ratios in excess of 0.02 in a single layer should not be used unless the amount and disposition of the reinforcement will not prevent the proper placement of the concrete in walls and at splices and junction members.

Reinforcement Detailing Constraints

For heavily loaded walls where reinforcement ratio is high, it is critical that reinforcement is detailed carefully to avoid congestion within the wall which creates difficulties when core filling and may result in voids or insufficient concrete compaction.

When detailing reinforcement to be placed in Logicwall® the following spacing constraints must be noted:

- For single reinforcement carrier walls the reinforcement is centrally placed at minimum horizontal centres as shown.

- For double reinforcement carrier walls, LW200D and LW262D, the reinforcement is located toward each face of the wall with concrete cover as shown.
- Typical total reinforcement rates are less than 0.01. Rates in excess of 0.02 are not recommended as it creates possible congestion issues.
- Areas with higher reinforcement concentrations such as laps and corners should be reviewed.

D2. LOGICWALL® Design For Earthquake Actions

Logicwall® is to be designed to cater for earthquake actions as per AS1170.4 Earthquake Actions and AS3600-2018 Section 14 Design for Earthquake Actions. The design and detailing of the wall will depend on the Structural System selected by the designer for

the building from Table 14.3 Structural Ductility Factor and Structural Performance Factor. This will normally be either Non-Ductile Structural Walls or Limited Ductile Structural Walls.

D3. Non Ductile Wall Design

The use of the Simplified Design Method in Section 11.5 is limited to Non-Ductile Walls by Cl 14.4.4.1 and Cl 11.5.2 Limitations on the use of the Method. Non-Ductile Logicwall® are to designed to Section 2.2 and 14.4.

14.4.4.1 General

"Walls shall be designed in accordance with Section 10 or Section 11 as appropriate except that the simplified design method for walls subjected to vertical compression forces provided in Clause 11.5 of this standard shall only be used for non-ductile walls."

Axial Capacity

AFS Logicwall® can be designed in accordance with Section 11 of AS3600 – 2018.

$$\phi N_u = \phi(t_w - 1.2e - 2e_a)0.6f_c \quad [\text{AS3600 Cl.11.5.3}]$$

Where:

$\phi = 0.65$ strength reduction factor

$N_u =$ ultimate strength per unit wall length

$t_w =$ thickness of the wall

$e =$ eccentricity of the load measured at right angles to the plane of the wall

$e_a = \frac{H_{we}^2}{2500t_w}$ an additional eccentricity

$H_{we} = kH_{wu}$ effective height of a braced wall

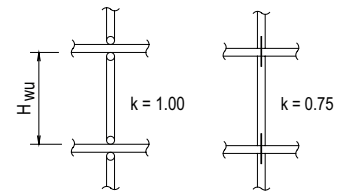

[AS3600 Cl.11.5.3]

11.5.2 Limitation on use of method

"Structural walls designed using Clause 11.5.3 Shall –

- be limited to a maximum design axial stress of 3 MPa unless vertical and horizontal reinforcement is provided on both wall faces and divided equally between the two wall faces;
- not constructed on sites with soil classifications of De or Ee, as defined in AS 1170.4, and where subjected to earthquake design actions; and
- have a ratio of effective height to thickness that does not exceed 20 for singly reinforced wall or 30 for doubly reinforced walls.

Otherwise, the wall shall be designed as a column in accordance with Section 10."

D3.1. LOGICWALL® LW120

LW120 Structural Capacities

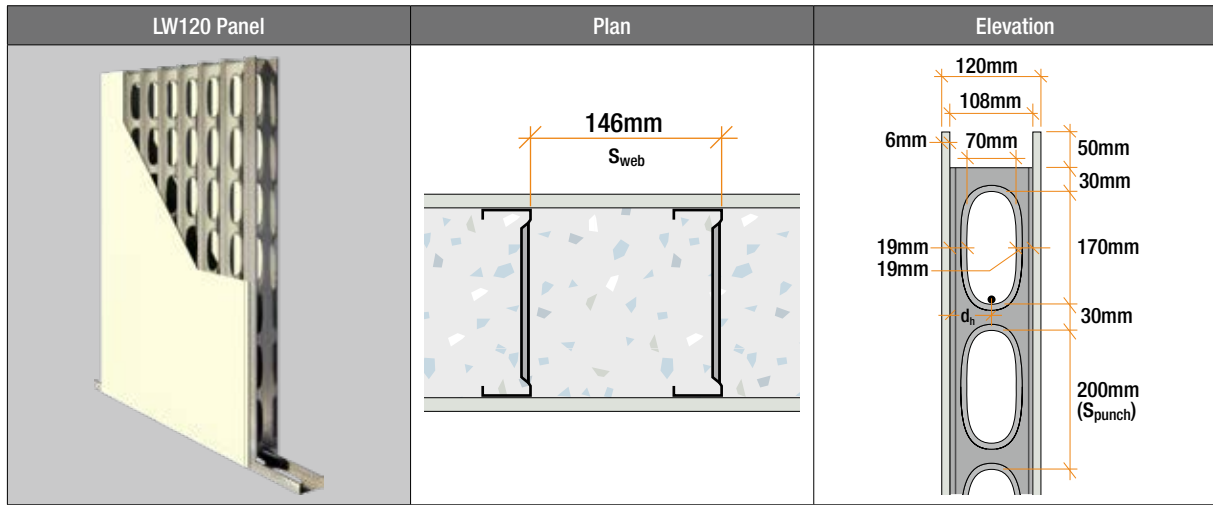

LW120 Axial Capacity ϕN_u (kN/m)

t_w	S_{web}	S_{punch}	A_c	N_{layers}	d_h	$f'_{c,max}$	Slend. Limit	Max. H_{wu}
108	146	200	47%	1	54	40	20	2880

H_{wu}	$k = 0.75$		$e \leq 1/6t_w$		
	H_{we}	25 MPa	32 MPa	40 MPa	
2880	2160	324*	324*	324*	
Limit with bottom plate		1001	1281	1601	

*AS3600-2018 Section 11.5.2 Limitations on use of Simplified Design Method

LW120 Reinforcement

LW120		Vertical Bars (min. N12 - 350)			
Allowable Bars		N12	N16	N20	N24
Horizontal Bars (min. N12 - 350)	N12				
	N16				
	N20				
	N24				

Horizontal Bar Spacing 200/300*/400
 Vertical Bar Spacing 150 to 350
 $f'_{c,max}$ 40 MPa, Concrete mix as per spec
 *Average spacing

Acceptable
With Caution
Not Recommended

LW120 Flexural Capacity

	Non Fire Rated Flexural Capacity, stud only		
	25 MPa	32 MPa	40 MPa
ϕM_u (kNm/m)	12.5	12.6	12.7

Non fire rated capacity, for local wind loads only (ignoring any extra reinforcement)

LW120 Standard Lintels

Capacity given is for standard lintel, with minimum reinforcement. Engineer can add extra reinforcement to achieve higher capacity.

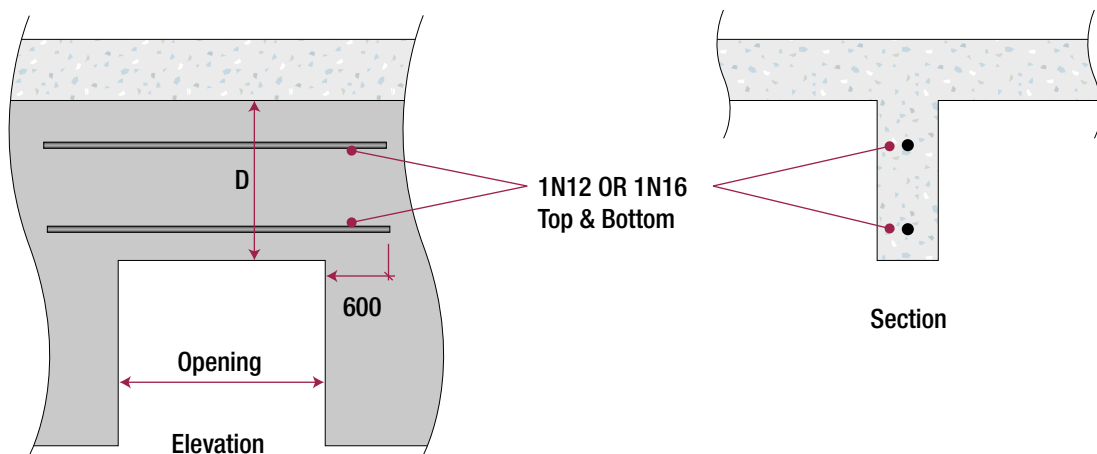

LW120 Standard Lintels with Vertical Studs UDL w^* (kN/m)

D	1N12 Top & Bottom, Depth (mm)					1N16 Top & Bottom, Depth (mm)				
	300	450	600	900	1200	300	450	600	900	1200
d_{eff}	200	350	500	800	1100	200	350	500	800	1100
Span (mm)										
3900	6.0	10.7	15.5	25.1	34.6	10.3	19.0	27.6	41.5	41.5
3600	7.0	12.6	18.2	29.4	38.0	12.1	22.3	32.4	45.0	45.0
3300	8.3	15.0	21.7	35.0	41.4	14.4	26.5	38.6	49.1	49.1
3000	10.1	18.2	26.2	38.7	45.6	17.4	32.0	46.7	54.0	54.0
2700	12.5	22.4	32.4	43.0	50.6	21.5	39.6	53.9	60.0	60.0
2400	15.8	28.4	39.8	48.4	57.0	27.2	50.1	60.6	67.5	67.5
2100	20.6	37.1	45.5	55.3	65.1	35.5	64.4	69.3	77.1	77.1
1800	28.1	47.3	53.1	64.5	75.9	48.3	75.1	80.9	90.0	90.0
1500	40.4	56.8	63.7	77.4	91.1	69.5	90.2	97.0	108.0	108.0
1200	62.4	71.0	79.6	96.7	113.9	104.1	112.7	121.3	135.0	135.0
900	83.2	94.7	106.1	129.0	151.9	138.8	150.3	161.7	180.0	180.0
ϕM_u (kNm/m)	8.3	14.9	21.5	34.7	47.9	14.2	26.2	38.2	62.2	86.2
$V_{u,max}$ (kN)	108.0	189.0	270.0	432.0	594.0	108.0	189.0	270.0	432.0	594.0
ϕV_u (kN)	37.4	42.6	47.7	58.0	68.3	62.5	67.6	72.8	81.0	81.0
	$f'_c = 25\text{MPa}, 50 \text{ cover (min)}$					$f'_c = 25\text{MPa}, 50 \text{ cover (min)}$				
	= Limited by shear									

Based on testing (Refer report No C2004-02, titled "Lateral load resistance of AFS wall panels" by University of Centerbury, NewZealand) with $\phi_{bend} = 0.8$, $\phi_{shear} = 0.7$ and k_{co} against steel = 0 as per clause 8.4.3 of AS3600-2018

D3.2. LOGICWALL® LW150

LW150 Structural Capacities

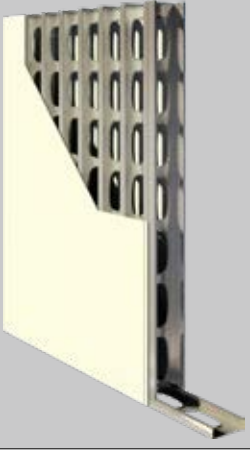
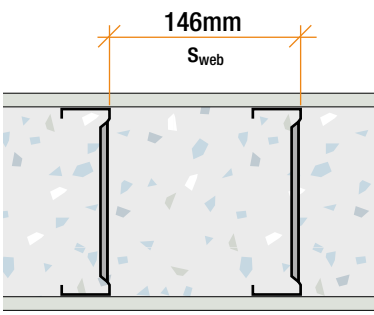
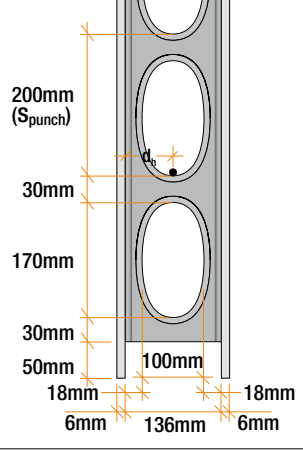
LW150 Panel			Plan			Elevation		
								
t_w	S_{web}	S_{punch}	A_c	N_{layers}	d_h	$f'_{c,max}$	Slend. Limit	Max. H_{wu}
136	146	200	52%	1	69	50	20	3630

LW150 Axial Capacity ϕN_u (kN/m)

H_{wu}	$k = 0.75$		$e \leq 1/6t_w$		
	H_{we}	25 MPa	32 MPa	40 MPa	50 MPa
3630	2720	408*	408*	408*	408*
Limit with bottom plate		1328	1700	2124	2656

*AS3600-2018 Section 11.5.2 Limitations on use of Simplified Design Method

LW150 Reinforcement

LW150		Vertical Bars (min. N12 - 325)			
Allowable Bars		N12	N16	N20	N24
Horizontal Bars (min. N12 - 350)	N12				
	N16				
	N20				
	N24				

Horizontal Bar Spacing 200/300*/400
 Vertical Bar Spacing 150 to 350
 $f'_{c,max}$ 40 MPa, Concrete mix as per spec
 *Average spacing

Acceptable
With Caution
Not Recommended

LW150 Flexural Capacity

	Non Fire Rated Flexural Capacity, stud only			
	25 MPa	32 MPa	40 MPa	50 MPa
ϕM_u (kNm/m)	15.9	16.0	16.0	16.1

Non fire rated capacity, for local wind loads only (ignoring any extra reinforcement)

LW150 Standard Lintels

Capacity given is for standard lintel, with minimum reinforcement. Engineer can add extra reinforcement to achieve higher capacity.

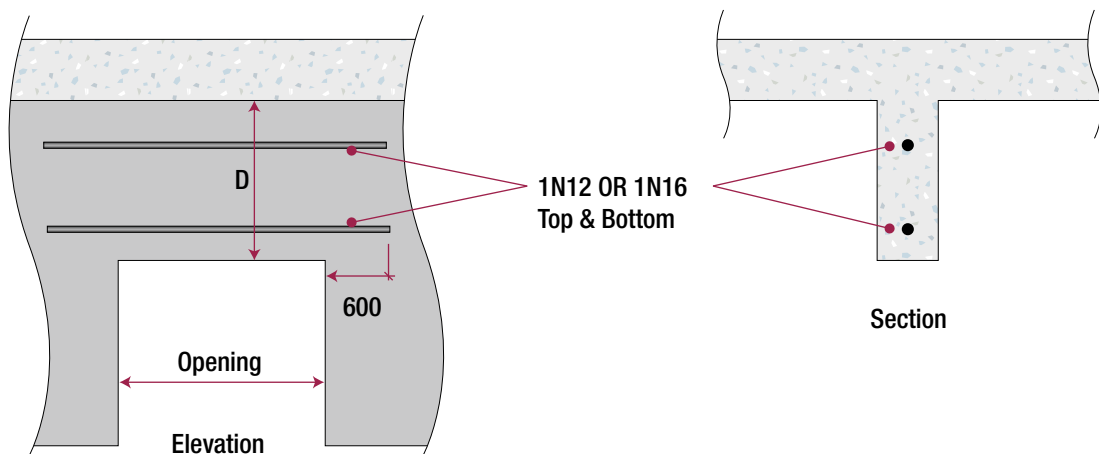

LW150 Standard Lintels with Vertical Studs UDL w^* (kN/m)

D	1N12 Top & Bottom, Depth (mm)					1N16 Top & Bottom, Depth (mm)				
	300	450	600	900	1200	300	450	600	900	1200
d_{eff}	200	350	500	800	1100	200	350	500	800	1100
Span (mm)										
3900	6.1	10.8	15.6	25.1	34.7	10.6	19.2	27.9	45.3	52.3
3600	7.1	12.7	18.3	29.5	40.7	12.4	22.6	32.8	52.9	56.7
3300	8.5	15.1	21.8	35.1	48.5	14.7	26.9	39.0	57.7	61.8
3000	10.2	18.3	26.4	42.5	56.0	17.8	32.5	47.2	63.5	68.0
2700	12.6	22.6	32.6	51.6	62.2	22.0	40.1	58.2	70.5	75.6
2400	16.0	28.6	41.2	58.0	70.0	27.9	50.8	67.3	79.3	85.0
2100	20.9	37.3	52.6	66.3	80.0	36.4	66.3	76.9	90.6	97.1
1800	28.4	50.8	61.4	77.4	93.4	49.5	81.7	89.7	105.8	113.3
1500	40.9	64.0	73.6	92.8	112.0	71.3	98.1	107.7	126.9	136.0
1200	64.0	80.0	92.0	116.1	140.1	110.6	122.6	134.6	158.6	170.0
900	90.7	106.7	122.7	154.7	186.7	147.5	163.5	179.5	211.5	226.7
ϕM_u (kNm/m)	8.4	15.0	21.6	34.8	48.0	14.6	26.6	38.6	62.6	86.6
$V_{u,max}$ (kN)	136.0	238.0	340.0	544.0	748.0	136.0	238.0	340.0	544.0	748.0
ϕV_u (kN)	40.8	48.0	55.2	69.6	84.0	66.4	73.6	80.8	95.2	102.0
	$f'_c = 25\text{MPa}, 50 \text{ cover (min)}$					$f'_c = 25\text{MPa}, 50 \text{ cover (min)}$				

Based on testing (Refer report No C2004-02, titled "Lateral load resistance of AFS wall panels" by University of Centerbury, NewZealand) with $\phi_{bend} = 0.8$, $\phi_{shear} = 0.7$ and k_{co} against steel = 0 as per clause 8.4.3 of AS3600-2018

D3.3. LOGICWALL® LW162

LW162 Structural Capacities

LW162 Panel		Plan		Elevation				
t_w	S_{web}	S_{punch}	A_c	N_{layers}	d_h	$f'_{c,max}$	Slend. Limit	Max. H_{wu}
150	146	200	47.2%	1	75	50	20	4000

LW162 Axial Capacity ϕN_u (kN/m)

H_{wu}	$k = 0.75$	$e \leq 1/6t_w$			
	H_{we}	25 MPa	32 MPa	40 MPa	50 MPa
4000	3000	450*	450*	450*	450*
Limit with bottom plate		1391	1781	2226	2782

*AS3600-2018 Section 11.5.2 Limitations on use of Simplified Design Method

LW162 Reinforcement

LW162		Vertical Bars (min. N12 - 300)			
Allowable Bars		N12	N16	N20	N24
Horizontal Bars min. N12 - 350)	N12	Acceptable	Acceptable	Acceptable	Not Recommended
	N16	Acceptable	Acceptable	With Caution	Not Recommended
	N20	Not Recommended	Not Recommended	Not Recommended	Not Recommended
	N24	Not Recommended	Not Recommended	Not Recommended	Not Recommended

Horizontal Bar Spacing 200/300*/400
 Vertical Bar Spacing 150 to 350
 $f'_{c,max}$ 50 MPa, Concrete mix as per spec
 *Average spacing

Acceptable
With Caution
Not Recommended

LW162 Flexural Capacity

	Non Fire Rated Flexural Capacity, stud only			
	25 MPa	32 MPa	40 MPa	50 MPa
$\varnothing M_u$ (kNm/m)	17.6	17.7	17.7	17.8

Non fire rated capacity, for local wind loads only (ignoring any extra reinforcement)

LW162 Standard Lintels

Capacity given is for standard lintel, with minimum reinforcement. Engineer can add extra reinforcement to achieve higher capacity.

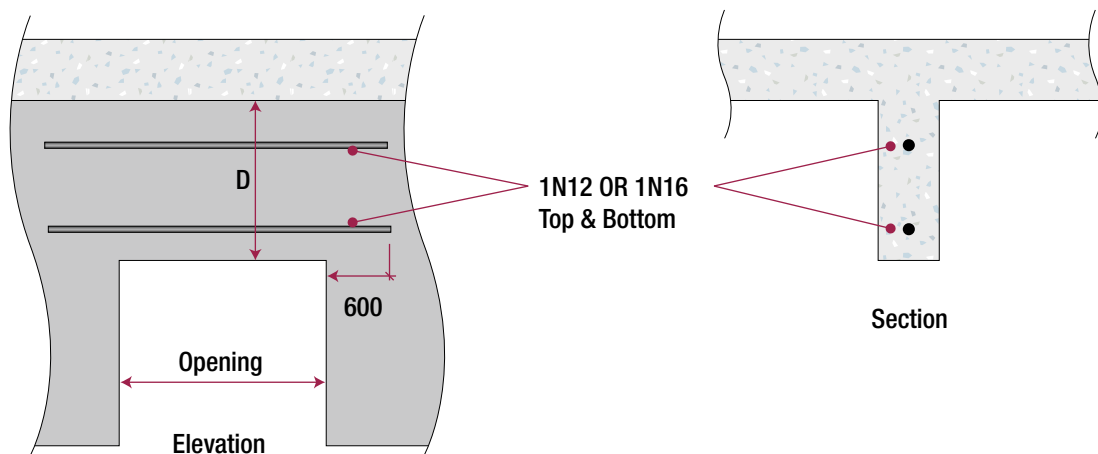

LW162 Standard Lintels with Vertical Studs UDL w^* (kN/m)

D	1N12 Top & Bottom, Depth (mm)					1N16 Top & Bottom, Depth (mm)				
	300	450	600	900	1200	300	450	600	900	1200
d_{eff}	200	350	500	800	100	200	350	500	800	100
Span (mm)										
3900	6.1	10.9	15.6	25.2	34.7	10.6	19.3	28.0	45.4	55.5
3600	7.1	12.7	18.3	29.5	40.8	12.5	22.7	32.9	52.1	60.1
3300	8.5	15.2	21.8	35.2	48.5	14.9	27.0	39.1	56.9	65.6
3000	10.3	18.3	26.4	42.5	55.4	18.0	32.7	47.3	62.6	72.1
2700	12.7	22.7	32.6	51.0	61.6	22.2	40.3	58.4	69.5	80.1
2400	16.1	28.7	41.3	57.4	69.3	28.1	51.0	66.3	78.2	90.2
2100	21.0	37.4	51.9	65.5	79.2	36.7	66.6	75.7	89.4	103.0
1800	28.6	51.0	60.5	76.5	92.4	50.0	80.4	88.4	104.3	120.2
1500	41.1	63.1	72.6	91.8	110.9	72.0	96.5	106.0	125.1	144.3
1200	64.3	78.9	90.8	114.7	138.6	108.6	120.6	132.5	156.4	180.3
900	89.2	105.2	121.1	152.9	184.8	144.8	160.8	176.7	208.6	240.4
$\varnothing M_u$ (kNm)	8.4	15.0	21.6	34.8	48.0	14.7	26.7	38.7	62.7	86.7
$V_{u,max}$ (kN)	150.0	262.5	375.0	600.0	825.0	150.0	262.5	375.0	600.0	825.0
$\varnothing V_u$ (kN)	40.1	47.3	54.5	68.8	83.2	65.2	72.3	79.5	93.9	108.2
	$f'_c = 25\text{MPa}$, 50 cover (min) for all w^* tables					$f'_c = 25\text{MPa}$, 50 cover (min) for all w^* tables				

Based on testing (Refer report No C2004-02, titled "Lateral load resistance of AFS wall panels" by University of Centerbury, NewZealand) with $\varnothing_{bend} = 0.8$, $\varnothing_{shear} = 0.7$ and k_{CO} against steel = 0 as per clause 8.4.3 of AS3600-2018

D3.4. LOGICWALL® LW200 & LW200D

LW200D Structural Capacities

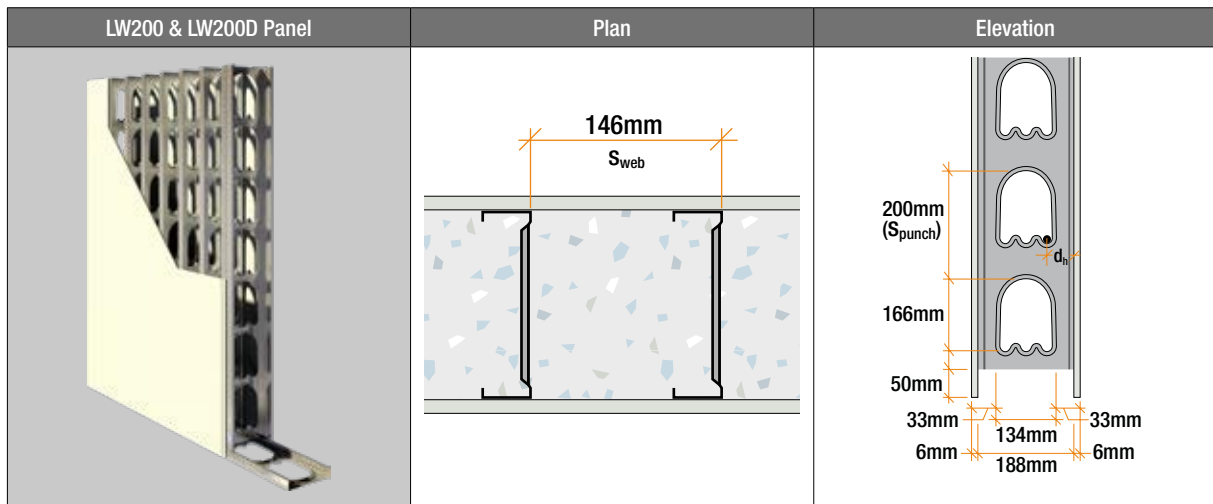

LW200

t_w	S_{web}	S_{punch}	A_c	N_{layers}	d_h	$f'_{c,max}$	Slend. Limit	Max. H_{wu}
188	146	200	50.0%	1	94	50	20	5010

LW200D

t_w	S_{web}	S_{punch}	A_c	N_{layers}	d_h	$f'_{c,max}$	Slend. Limit	Max. H_{wu}
188	146	200	50.0%	2	41	65	30	7520

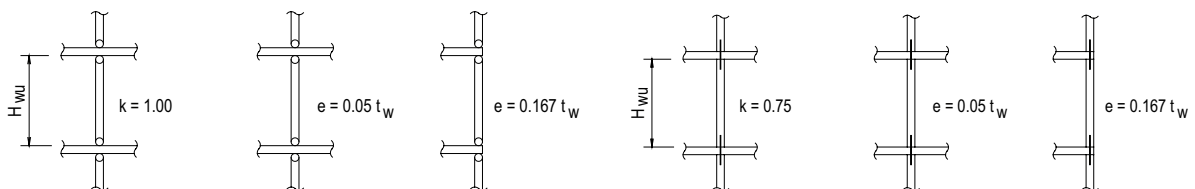

LW200 Axial Capacity ϕN_u (kN/m) Non-Ductile 1 Layers

H_{wu}	$k = 0.75$	Discontinuous Floor $e \leq 1/6t_w$			
		H_{we}	25 MPa	32 MPa	40 MPa
5010	3760	564*	564*	564*	564*
Limit with bottom plate		1742	2230	2787	3859

*AS3600-2018 Sect 11.5.2 Limitations on use of Simplified Design Method

LW200D Axial Capacity ϕN_u (kN/m) Non-Ductile 2 Layers

H_{wu}	$k = 0.75$ H_{we}	Continuous Floor $e = 0.05t_w$					Discontinuous Floor $e \leq 1/6t_w$				
		25 MPa	32 MPa	40 MPa	50 MPa	65 MPa	25 MPa	32 MPa	40 MPa	50 MPa	65 MPa
6000	4500	883	1130	1413	1766	2295	626	802	1002	1252	1628
5000	3750	1140	1459	1823	2279	2963	883	1130	1413	1766	2296
4500	3375	1250	1601	2001	2501	3251	994	1272	1590	1988	2584
4200	3150	1311	1679	2098	2623	3409	1055	1350	1688	2109	2742
3900	2925	1368	1751	2189	2736	3557	1111	1423	1778	2223	2890
3600	2700	1421	1818	2273	2841	3693	1164	1490	1862	2328	3026
3300	2475	1469	1880	2350	2938	3819	1212	1552	1940	2425	3152
3000	2250	1513	1937	2421	2026	3934	1256	1608	2010	2513	3267
2700	2025	1553	1988	2485	3106	4038	1296	1659	2074	2593	3370
2400	1800	1589	2033	2542	3177	4130	1332	1705	2131	2664	3463
2100	1575	1620	2074	2592	3240	4212	1363	1745	2182	2727	3545
1800	1350	1647	2109	2636	3295	4283	1391	1780	2225	2782	3616
Limit with bottom plate		1795	2297	2871	3589	4666	1795	2297	2871	3589	4666

Bottom plate may be deleted by the designer

LW200 Reinforcement

LW200		Vertical Bars (min. N12 - 350)			
Allowable Bars		N12	N16	N20	N24
Horizontal Bars (min. N12 - 350)	N12	Acceptable	Acceptable	Acceptable	With Caution
	N16	Acceptable	Acceptable	Acceptable	With Caution
	N20	With Caution	With Caution	With Caution	Not Recommended
	N24	Not Recommended	Not Recommended	Not Recommended	Not Recommended

Horizontal Bar Spacing 200/300*/400
 Vertical Bar Spacing 150 to 350
 $f'_{c,max}$ 65 MPa, Concrete mix as per spec

Acceptable
With Caution
Not Recommended

LW200D Reinforcement

LW200D##		Vertical Bars Each Face (min. N12 - 350)			
Allowable Bars		N12	N16	N20	N24
Horizontal Bars Each Face (min. N12 - 350)	N12	Acceptable	Acceptable	Acceptable	With Caution
	N16	Acceptable	Acceptable	Acceptable	With Caution
	N20	With Caution	With Caution	With Caution	Not Recommended
	N24	Not Recommended	Not Recommended	Not Recommended	Not Recommended

Horizontal Bar Spacing 200/300*/400
 Vertical Bar Spacing 150 to 350
 $f'_{c,max}$ 65 MPa, Concrete mix as per spec
 ##Double layer only if specified by project engineer otherwise LW200 preferred.
 *Average spacing

Acceptable
With Caution
Not Recommended

LW200 & LW200D Flexural Capacity

	Non Fire Rated Flexural Capacity, stud only				
	25 MPa	32 MPa	40 MPa	50 MPa	65 MPa
ϕM_u (kNm/m)	22.8	22.3	22.3	22.4	22.4

Non fire rated capacity, for local wind loads only (ignoring any extra reinforcement)

LW200D Double Reinforcement Lintels

Capacity given is for standard lintel, with minimum reinforcement. Engineer can add extra reinforcement to achieve higher capacity.

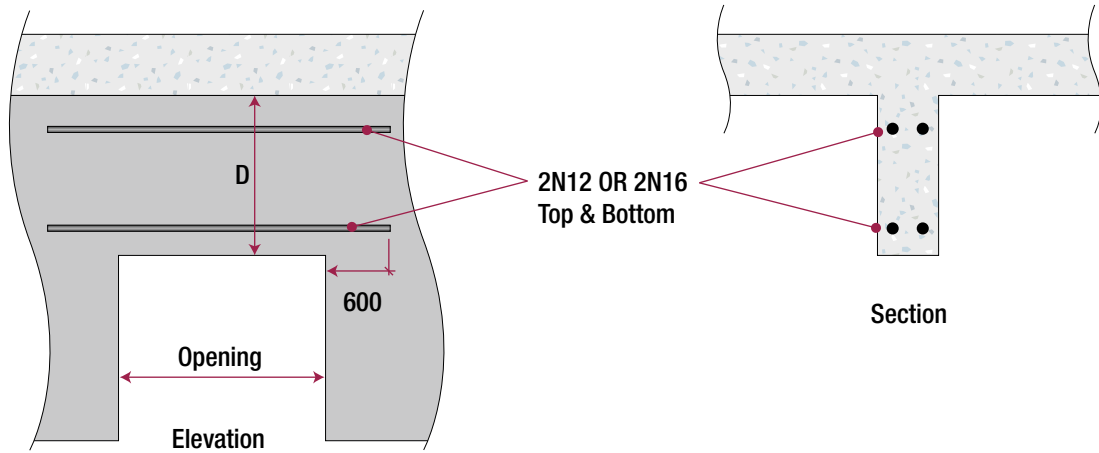

LW200D Standard Lintels with Vertical Studs UDL $w^*(\text{kN/m})$

D	2N12 Top & Bottom, Depth (mm)					2N16 Top & Bottom, Depth (mm)				
	300	450	600	900	1200	300	450	600	900	1200
d_{eff}	200	350	500	800	1100	200	350	500	800	1100
Span (mm)										
3900	11.8	21.4	30.9	50.0	67.5	20.2	37.5	54.9	72.3	72.3
3600	13.9	25.1	36.3	58.7	73.2	23.7	44.1	64.4	78.3	78.3
3300	16.5	29.9	43.2	68.3	79.8	28.2	52.4	76.7	85.5	85.5
3000	20.0	36.1	52.3	75.1	87.8	34.1	63.5	92.8	94.0	94.0
2700	24.7	44.6	64.5	83.4	97.5	42.1	78.3	104.4	104.4	104.4
2400	31.3	56.5	78.0	93.9	109.7	53.3	99.1	117.5	117.5	117.5
2100	40.8	73.7	89.1	107.3	125.4	69.6	128.3	134.3	134.3	134.3
1800	55.6	93.4	104.0	125.2	146.3	94.8	149.7	156.7	156.7	156.7
1500	80.0	112.1	124.8	150.2	175.6	136.5	179.6	188.0	188.0	188.0
1200	124.3	140.1	156.0	187.7	219.5	208.7	224.5	235.0	235.0	235.0
900	165.7	186.9	208.0	250.3	292.6	278.2	299.4	313.3	313.3	313.3
$\varnothing M_u (\text{kNm})$	16.4	29.6	42.8	69.2	95.6	27.9	51.9	75.9	123.9	171.9
$V_{u,\text{max}} (\text{kN})$	188.0	329.0	470.0	752.0	1034.0	188.0	329.0	470.0	752.0	1034.0
$\varnothing V_u (\text{kN})$	74.6	84.1	93.6	112.6	131.7	125.2	134.7	141.0	141.0	141.0
	$f'_c = 25\text{MPa}, 50 \text{ cover (min)}$					$f'_c = 25\text{MPa}, 50 \text{ cover (min)}$				
	= Limited by shear									

Based on testing (Refer report No C2004-02, titled "Lateral load resistance of AFS wall panels" by University of Centerbury, New Zealand) with $\varnothing_{\text{bend}} = 0.8$, $\varnothing_{\text{shear}} = 0.7$ and k_{co} against steel = 0 as per clause 8.4.3 of AS3600-2018

D3.5. LOGICWALL® LW262D

LW262D Structural Capacities

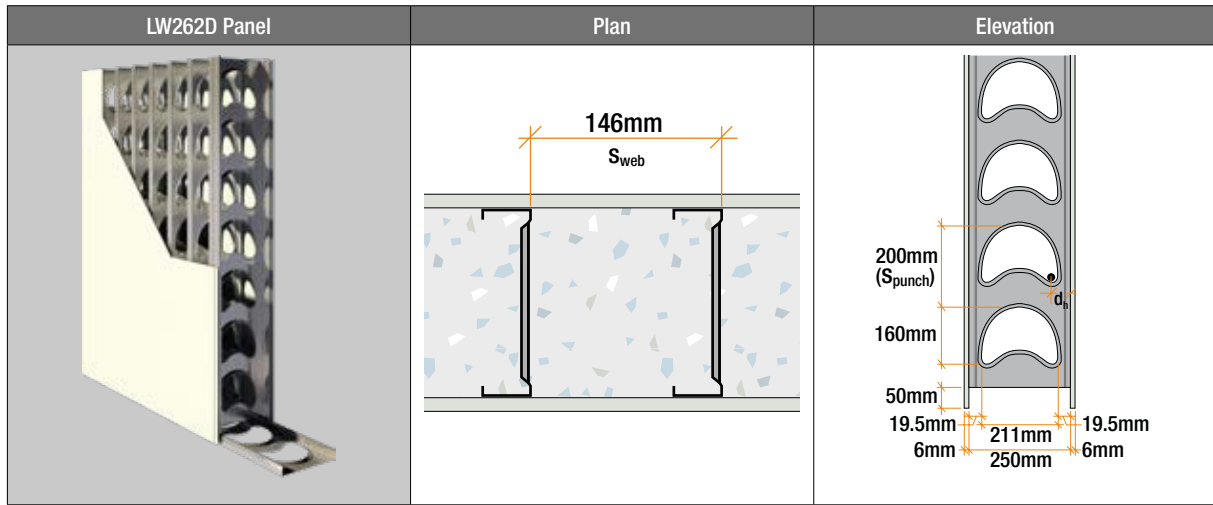

t_w	S_{web}	S_{punch}	A_c	N_{layers}	d_n	$f'_{c,max}$	Slend. Limit	Max. H_{wu}
250	146	200	50.0%	2	45	65	30	10,000

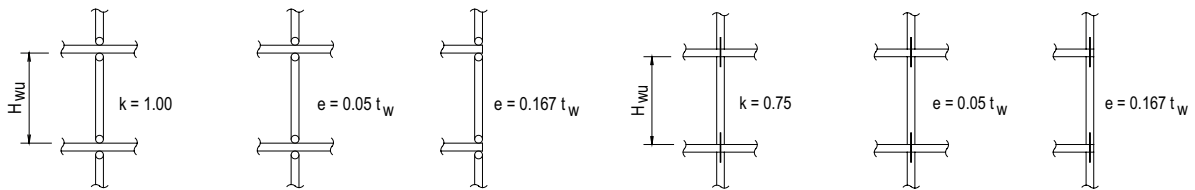

LW262D Axial Capacity ϕN_u (kN/m) Non-Ductile 2 layers

H_{wu}	$k = 0.75$	Continuous Floor $e = 0.05t_w$					Discontinuous Floor $e \leq 1/6t_w$				
		H_{we}	25 MPa	32 MPa	40 MPa	50 MPa	65 MPa	25 MPa	32 MPa	40 MPa	50 MPa
6000	4500	1659	2124	2655	3319	4315	1318	1687	2109	2636	3427
5000	3750	1853	2371	2964	3705	4817	1511	1934	2418	3023	3929
4500	3375	1936	2478	3097	3872	5033	1595	2041	2551	3189	4146
4200	3150	1982	2537	3171	3963	5152	1640	2100	2625	3281	4265
3900	2925	2024	2591	3239	4049	5263	1683	2154	2693	3366	4376
3600	2700	2064	2642	3302	4128	5366	1723	2205	2756	3445	4479
3300	2475	2100	2688	3360	4200	5460	1759	2251	2814	3518	4573
3000	2250	2133	2731	3413	4267	5547	1792	2294	2867	3584	4659
2700	2025	2163	2769	3461	4327	5625	1822	2332	2915	3644	4737
2400	1800	2190	2803	3504	4380	5694	1849	2367	2958	3698	4807
2100	1575	2214	2834	3542	4428	5756	1873	2397	2996	3745	4869
1800	1350	2234	2860	3575	4469	5809	1893	2423	3029	3786	4922
Limit with bottom plate		2375	3039	3799	4749	6174	2375	3039	3799	4749	6174

Bottom plate may be deleted by the designer

LW262D Reinforcement

LW262D		Vertical Bars Each Face (min. N12 - 350)			
Allowable Bars		N12	N16	N20	N24
Horizontal Bars Each Face (min. N12 - 350)	N12				
	N16				
	N20				
	N24				

Horizontal Bar Spacing 200/300*/400
 Vertical Bar Spacing 150 to 350
 $f'_{c,max}$ 65 MPa, Concrete mix as per spec
 *Average spacing

Acceptable
With Caution
Not Recommended

LW262D Flexural Capacity

	Non Fire Rated Flexural Capacity, stud only				
	25 MPa	32 MPa	40 MPa	50 MPa	65 MPa
ϕM_u (kNm/m)	29.7	29.7	29.8	29.8	29.9

Non fire rated capacity, for local wind loads only (ignoring any extra reinforcement)

LW262D Double Reinforcement Lintels

Capacity given is for standard lintel, with minimum reinforcement. Engineer can add extra reinforcement to achieve higher capacity.

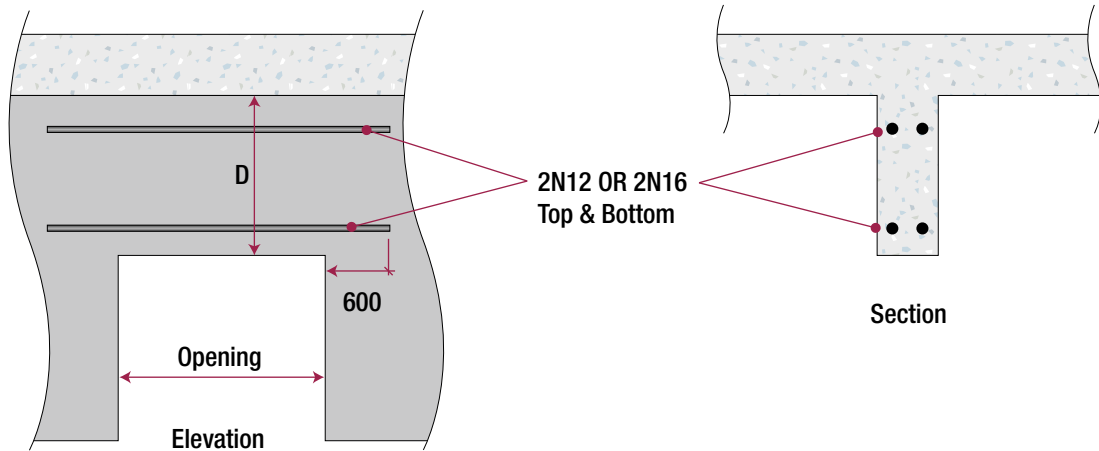

RW262C Standard Lintels with Vertical Studs UDL $w^*(\text{kN/m})$

D	2N12 Top & Bottom, Depth (mm)					2N16 Top & Bottom, Depth (mm)					
	300	450	600	900	1200	300	450	600	900	1200	
d_{eff}	242	392	542	842	1142	242	392	542	842	1142	
Span (mm)											
3900	12.1	21.6	31.1	50.2	69.3	20.9	38.3	55.6	90.3	96.2	
3600	14.1	25.4	36.6	59.0	81.4	24.6	44.9	65.3	99.5	104.2	
3300	16.8	30.2	43.5	70.2	93.1	29.2	53.5	77.7	108.5	113.6	
3000	20.4	36.5	52.6	84.9	102.4	35.4	64.7	94.0	119.4	125.0	
2700	25.2	45.1	65.0	95.2	113.8	43.6	79.9	114.1	132.7	138.9	
2400	31.8	57.0	82.3	107.1	128.0	55.2	101.1	128.4	149.3	156.3	
2100	41.6	74.5	98.6	122.5	146.3	72.2	132.0	146.7	170.6	178.6	
1800	56.6	101.1	115.0	142.9	170.7	98.2	157.2	171.2	199.0	208.3	
1500	81.5	121.3	138.0	171.4	204.8	141.4	188.7	205.4	238.8	250.0	
1200	127.3	151.6	172.5	214.3	256.1	215.0	235.9	256.7	298.5	312.5	
900	174.4	202.2	230.0	285.7	341.4	286.6	314.5	342.3	398.0	416.7	
$\emptyset M_u (\text{kNm})$	16.7	29.9	43.1	69.5	95.9	28.9	52.9	76.9	124.9	172.9	
$V_{u,\text{max}} (\text{kN})$	250.0	437.5	625.0	1000.0	1375.0	250.0	437.5	625.0	1000.0	1375.0	
$\emptyset V_u (\text{kN})$	78.5	91.0	103.5	128.6	153.6	129.0	141.5	154.0	179.1	187.5	
	$f'_c = 25\text{MPa}, 50 \text{ cover (min)}$					$f'_c = 25\text{MPa}, 50 \text{ cover (min)}$					
	= Limited by shear										

Based on testing (Refer report No C2004-02, titled "Lateral load resistance of AFS wall panels" by University of Centerbury, New Zealand) with $\emptyset_{\text{bend}} = 0.8$, $\emptyset_{\text{shear}} = 0.7$ and k_{co} against steel = 0 as per clause 8.4.3 of AS3600-2018

D4. Non-Ductile Wall Detailing

Standard AFS Wall Detailing for Non-Ductile Wall Designs in accordance with AS3600-2018 Section 2.2 and the relevant clauses in Section 14.4.

Junctions

In general Wall Junctions are not required to transfer of in plane Lateral or Shear loads across the junctions. Where transfer of in-plane Lateral or Shear loads across junctions is required the Project Engineer is

to specify the AFS Special Junction Details on the Structural Documentation. If detailing is required beyond these special junctions AFS Technical Support is to be consulted and detailing reviewed.

Standard wall junctions

Standard junctions are used except where the Structural Documentation indicates otherwise. Core Walls would generally be specified with special Junctions.

Standard Junctions – Single Reinforcement

Fig D1: Cross Junction

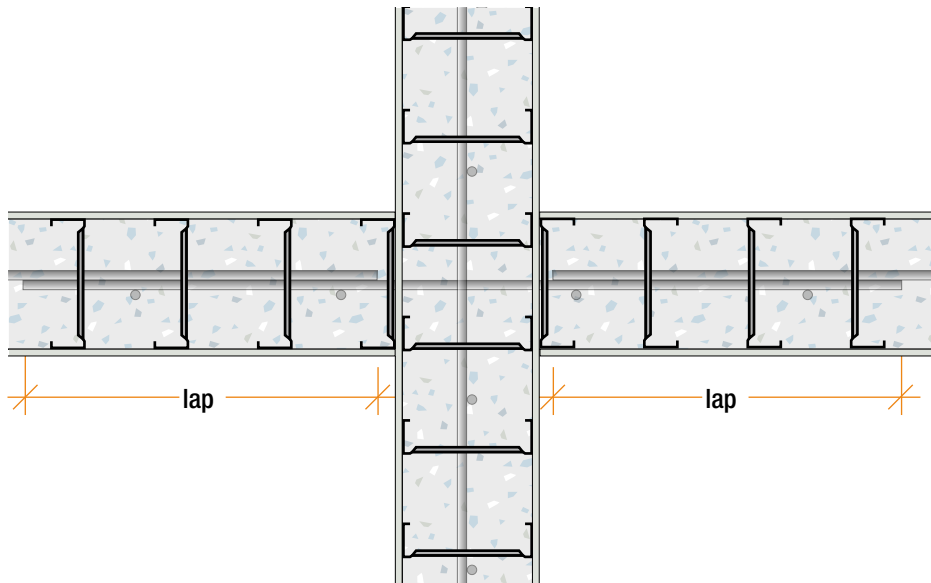

Fig D2: AFS Open Corner Capping

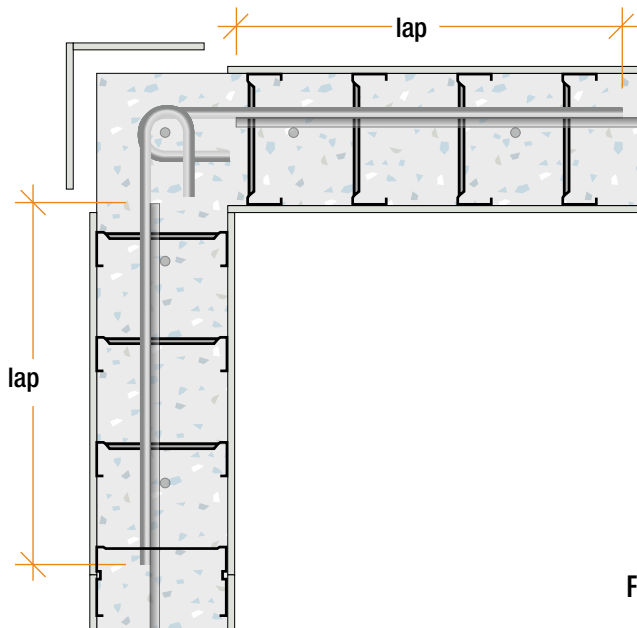

Fig D3: T Junction Capping

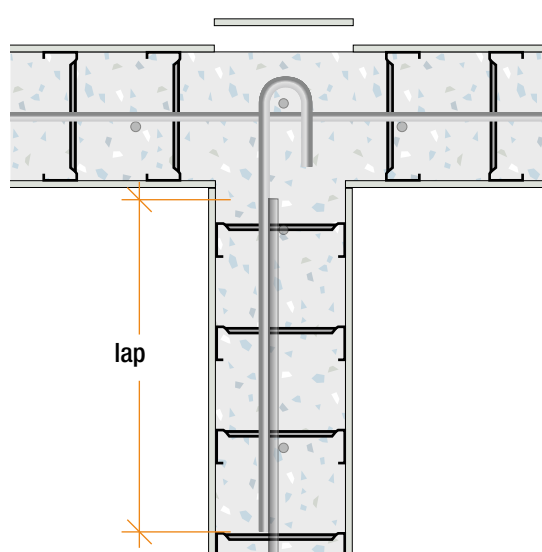

Fig D4: Standard Hook Bars

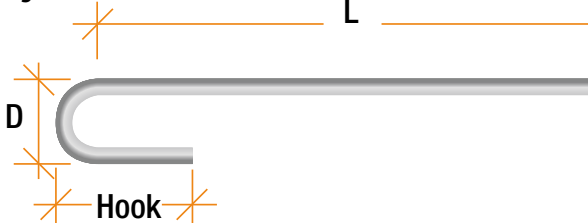

Fig D5: Angle Junction

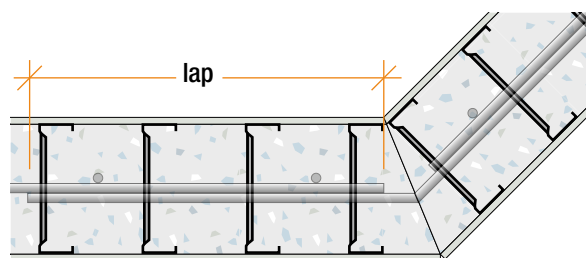

TABLE D7: Standard Hook Bar

Reo	D	L	Hook	Lap*	LW120	LW150	LW162	LW200
N12	72	550	70	450	Y	Y	Y	Y
N16	96	700	70	600	N	N	Y	Y
N20	120	900	70	800	N	N	N	Y

*non contact splice f'c>3sMPa, Cover ≥ 30 AS3600 C13.1.2, 13.2.2

General notes:

- Standard details used unless specified by structural documentation
- Horizontal wall reinforcement to be stopped clear of junction as shown

Standard Junctions – Double Reinforcement

Fig D6: Cross Junction

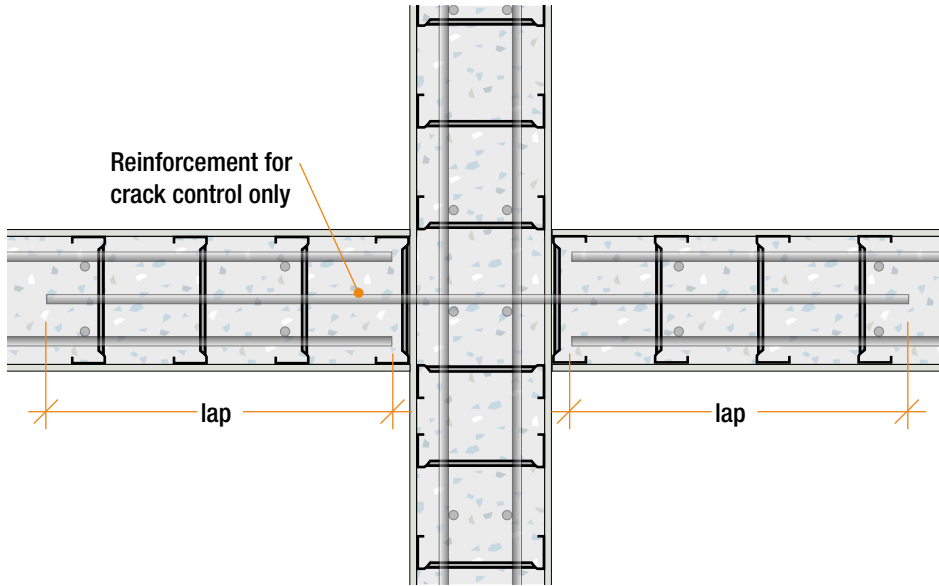

Fig D7: AFS Open Corner Capping

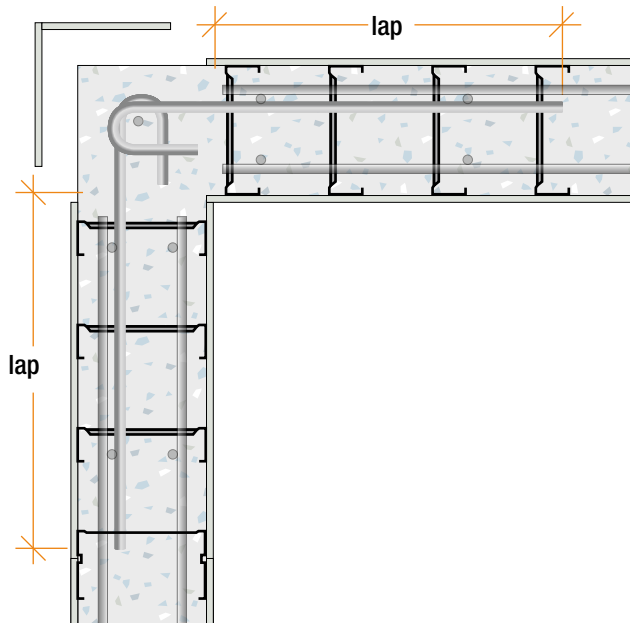
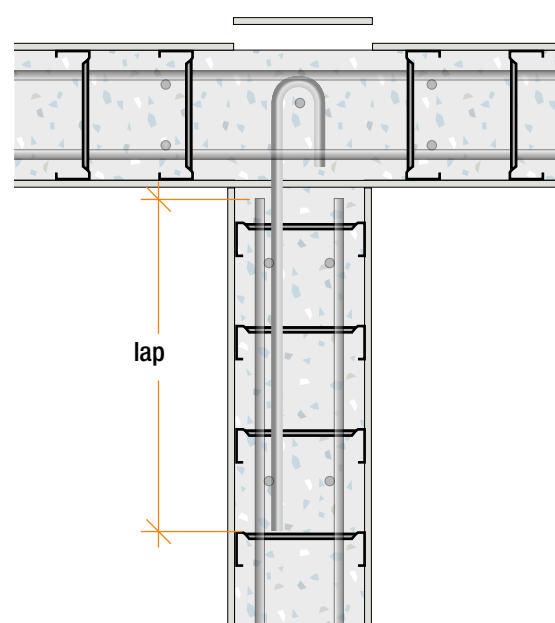

Fig D8: T Wall Junction Capping



Special junctions (where specified by the engineer)

Structural Documentation is to specify where Special Junctions are to be used. If detailing is required beyond these special junctions AFS Technical Support is to be consulted and detailing reviewed. Special Junctions are only available for Walls with two layers of reinforcement.

Special Junction Details will normally be specified for:

- Core Walls
- Deep Beams
- Any Junction transferring inplane Lateral or Shear Loads.

Special Junctions – Double Reinforcement

Fig D9: Cross Junction

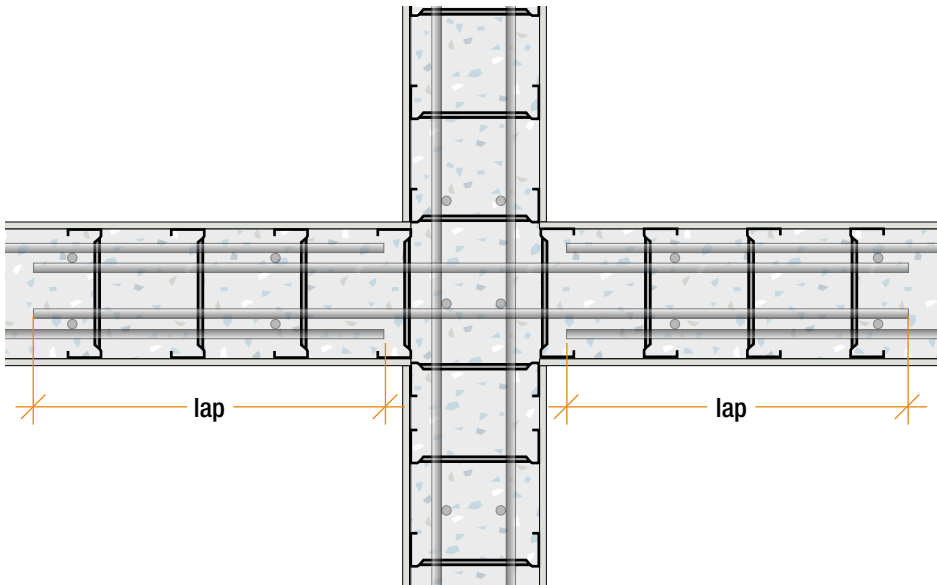

Fig D10: AFS Open Corner Capping

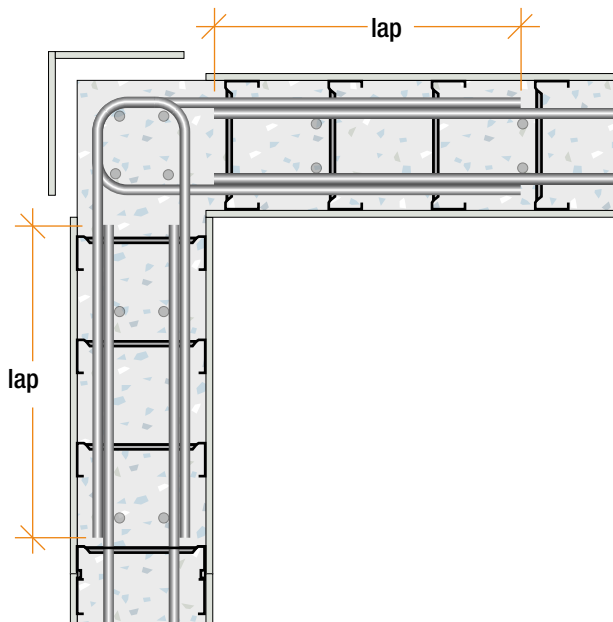

Fig D11: T Junction Capping

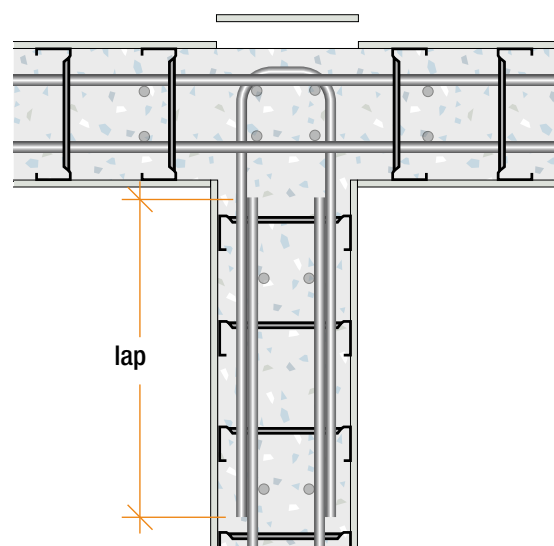

Fig D12: Standard U Bars

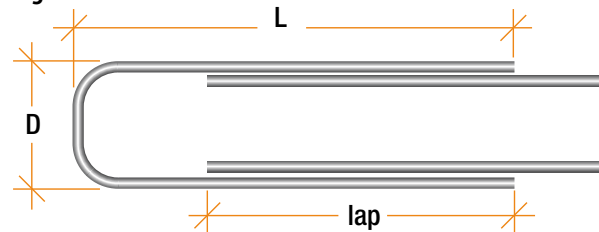

TABLE D8: Standard U Bar

Wall	Reo	D	L	Lap*
LW200D	N12	108	700	475
LW262D	N12	170	750	475
LW262D	N16	170	1050	750

*non contact splice $f_c > 32\text{MPa}$, Cover ≥ 30 AS3600 C13.1.2, 13.2.2

General notes:

- Standard details used unless specified by structural documentation
- Horizontal wall reinforcement to be stopped clear of junction as shown

Prefabricated Corners

Limited types of Prefabricated Corners are available on special order. These are limited by weight for fabrication and transport. Installation will require crane assistance.

Special Prefabricated AFS Logicwall® Corner Details

Fig D13: Standard L-Bar Factory Installed

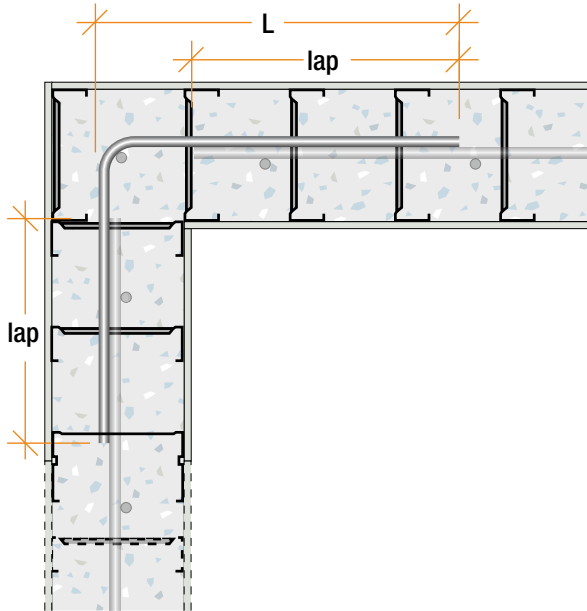

Fig D14: Standard L Bar

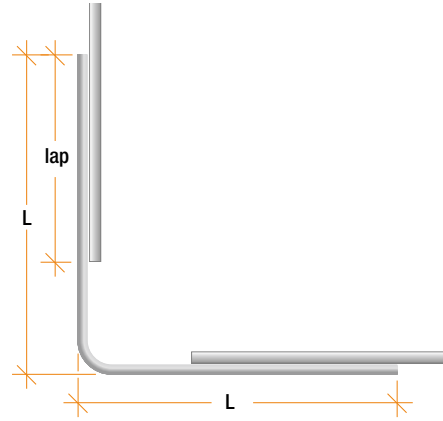

TABLE D9: Corner Bar

Corner Bar	L	Lap*
N12	700	450
N16	850	600
N20	1050	1050

* non contact splice $f'_c > 32\text{MPa}$,
Cover ≥ 30 AS3600 CL13.1.2, 13.2.2

TABLE D10: Prefabricated AFS Logicwall® Corner Bar Details "L"

Wall	Logicwall® Single Layer Corner Bar			Logicwall® Double Layer U Bar			Logicwall® Corner + 2 Cogged Bar N12
	N12	N16	N20	N12	N16	N20	
LW120	700	-	-	-	-	-	-
LW150	700	-	-	-	-	-	-
LW162	700	850	-	-	-	-	-
LW200	700	900	1100	700	850	-	750
LW262	-	-	-	750	900	1000	900

General notes:

- Details used unless specified by structural documentation
- Horizontal wall reinforcement to be stopped clear of junction as shown

Non-Ductile Blade Walls/Columns

AFS uses the following definitions for Blade Walls/Columns.

Blade walls

Blade walls are short walls designed as non-ductile walls without ligatures in accordance with Section 11 or as limited ductile less than 4 storeys as per Section 14, 11 and 10 of AS3600-2018. They are generally loaded concentrically, with concrete strength not greater than 50MPa and have no net tension in the strong or weak axis.

Fig A15: Logicwall® Blade Wall

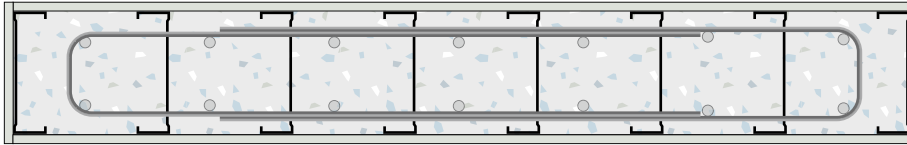

Blade Columns

Are short wall designed as columns with ligatures to AS3600-2018 Sections 14 and 10.

Fig A16: Logicwall® Blade Column

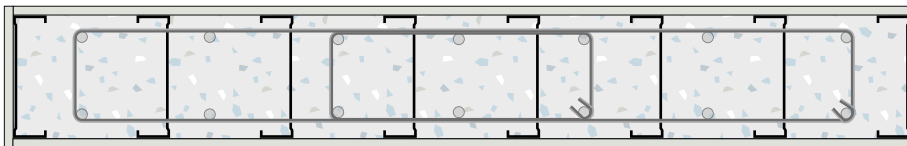

Joints

Various AFS standard joints may be specified on the by the Engineer on the Structural Documentation for non ductile walls as shown in the following sections

Sheet Surface Joint

Sheet surface joints are 6mm deep, (i.e. the full depth of the fibre cement sheet) to accommodate expansion the fibre cement sheet. These should be placed at max. 6.0m centres at the finishing stage, i.e. after wall is concrete filled at the time of setting the vertical

recessed joints. Locations of sheet surface joints should be nominated by architect, as they can often be concealed behind glazing sections of cupboards. Fig D17 shows details of Logicwall® sheet surface joint.

Fig D17: Logicwall® Sheet Surface Joint

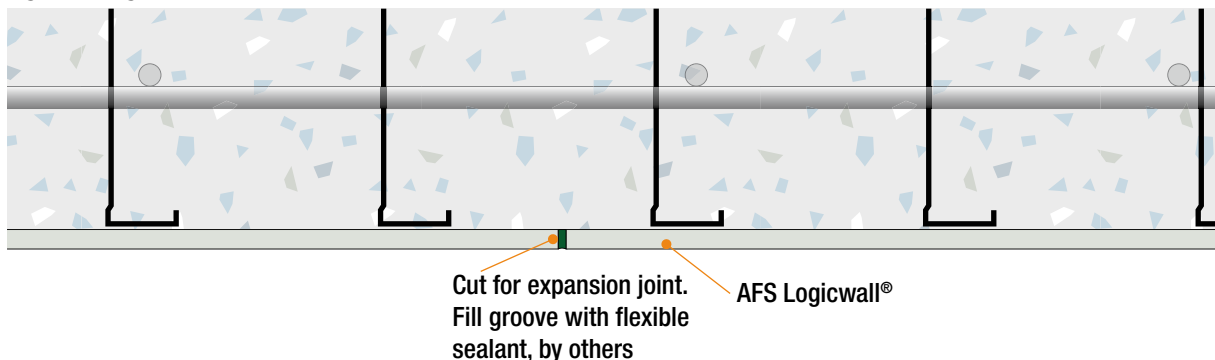

Movement Joints

Movements joints will be required where specified in the project documentation. The structural concrete wall effectively has control joints at each stud so no additional crack control joints are necessary. Full depth "movement joints" may be required depending on the geometry of the structure and other considerations such as thermal loads, exposure and building joints. In general "movement joints" would not be required for

walls less than 16m long. Structural movement joints will be placed in locations nominated by the structural engineer and must be documented on structural drawings. These will be installed at construction stage by the AFS Logicwall® installation contractor. Fig D18 shows details of Logicwall® movement joint.

Fig D18: logicwall® Movement joint

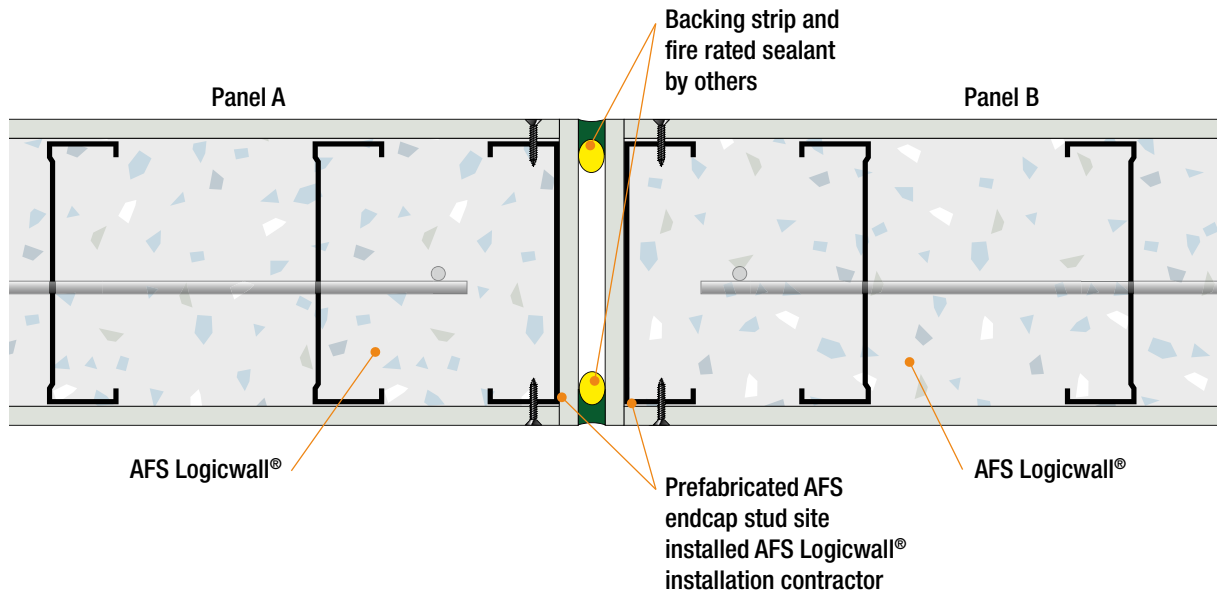

Note: Can be dowel jointed if required structurally. Must be clearly specified and negotiated with installers at time of tender. Installed where nominated by project engineer. Must be clearly documented on drawings. Typically not required in walls less than 16m in length.

Junction Joints to structurally isolate walls either side of the junction and prevent transfer of inplane forces.

Fig D19: Logicwall® Corner Joint

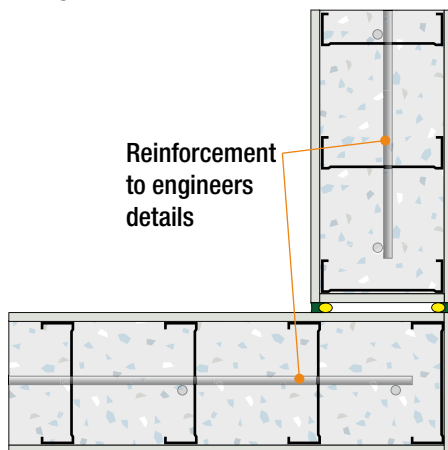
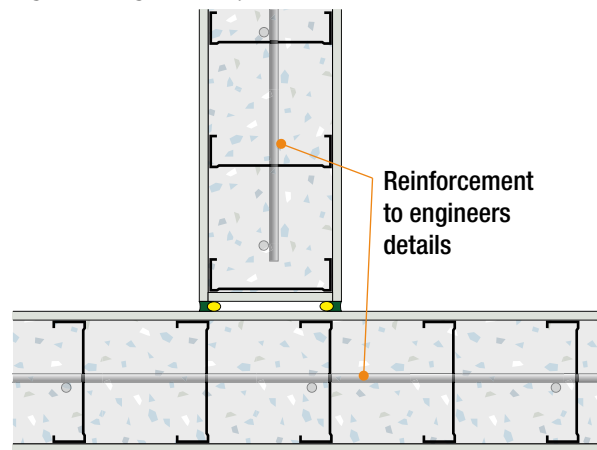

Fig D20: Logicwall® T joint



Construction Joint

Construction Joints can be used wherever a pour break is required, walls may be split to prevent transfer of in-plane forces. Locations are to be specified on the Project Documentation.

Fig D21: Logicwall® Construction Joint

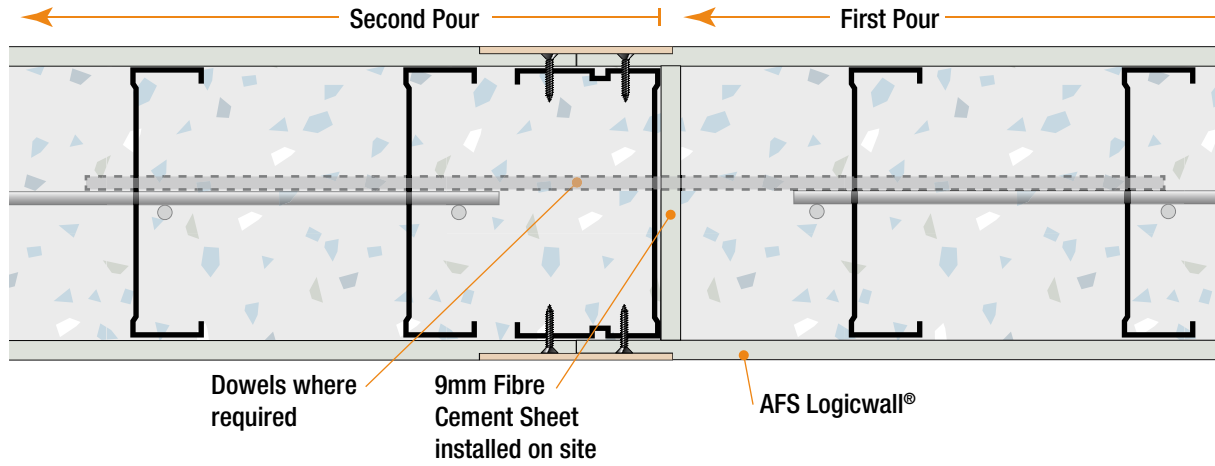

D5. Limited Ductile Wall Design

Limited Ductile Design

AFS Logicwall® can be designed to the requirements of AS3600-2018 Limited Ductile Walls. Limited Ductile Walls are to be designed to Section 2.2, Clause 14.4 and Clause 14.6 of AS3600-2018. Clause 14.6.1 requires the Limited Ductile walls to have reinforcement on each face and be detailed in accordance with the requirements of Clause 14.6.

Refer to the following sections for standard detailing to suit Logicwall® Limited Ductile Walls with boundary elements.

AFS Limited Ductile Walls are only to be installed by AFS approved experienced installers due to the additional detailing requirements. AFS detailing is to be used unless AFS Technical Support reviews and approves alternate detailing.

Below is a sample Moment Interaction curve showing LW200 capacity without core confinement

Fig D22: Sample Moment Interaction

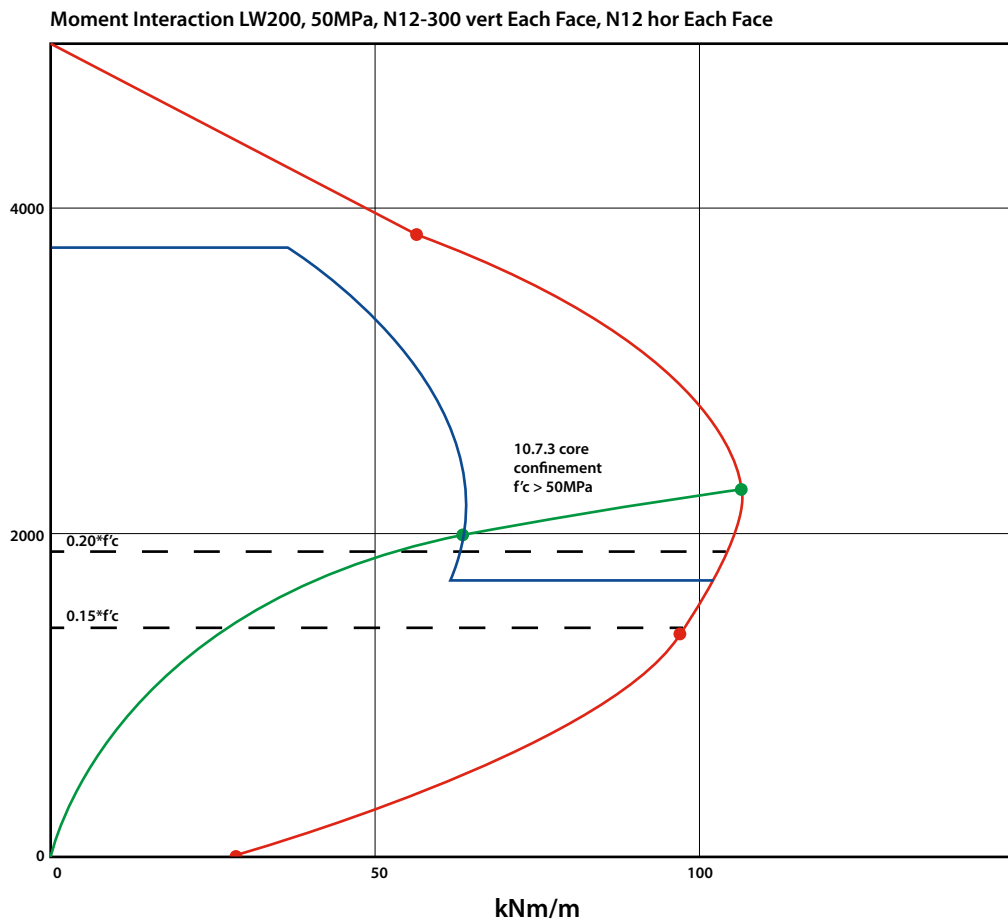

Limited Ductile Design Examples

The table below provides other design examples for Logicwall® over a range of reinforcement and concrete strengths.



	Panel	Plan	Elevation
LW200			
LW262D			

TABLE D11: Logicwall® Panel Properties

Wall Type	t_w	t_{fire}	N_{layers}	Slend. Limit	d_n	$f'_{c,max}$	A_c	Minimum Reinforcement
LW200D	188	146	2	30	41	50	50.0%	N12-200 Hor. N12-300 Vert.
LW262D	250	260	2	30	45	50	49.5%	N12-200 Hor. N12-375 Vert.

TABLE D12: Logicwall® Design Axial Force

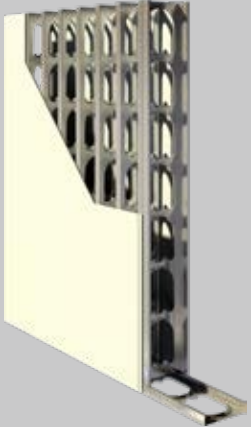
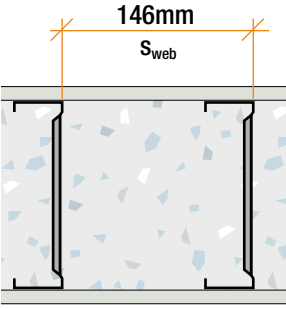
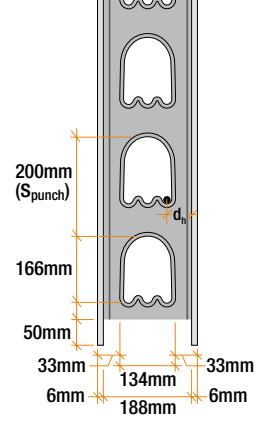
Wall Description	CI 11.7.4	H_{wu} K=0.75 (mm)	t_w (mm)	d_c (mm)	ρ	$\emptyset N_u$ $\emptyset N$ (CI 10.7.3) (kN/m)	14.6.2.1 $0.15 \cdot f'_c$ (kN/m)
LW200, 32MPa, N12-300 vertical Each Face, N12 Horizontal	Each Face (<1%)	3000	188	53	0.0040	1560 (-)	902
LW200, 50MPa, N12-300 vertical Each Face, N12 Horizontal	Each Face (<1%)	3000	188	53	0.0040	2250 (-)	1410
LW200, 50MPa, N16-220 vertical Each Face, N12 Horizontal	Each Face (<1%)	3000	188	53	0.0097	2370 (-)	1410
LW262, 32MPa, N12-300 vertical Each Face, N12 Horizontal	Each Face (<1%)	3000	250	57	0.0030	3040 (-)	1200
LW262, 50MPa, N12-300 vertical Each Face, N12 Horizontal	Each Face (<1%)	3000	250	57	0.0030	4470 (-)	1875
LW262, 50MPa, N20-250 vertical Each Face, N12 Horizontal	Each Face (<1%)	3000	250	61	0.0100	4820 (-)	1875

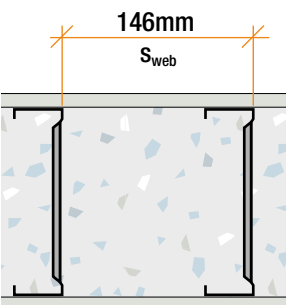
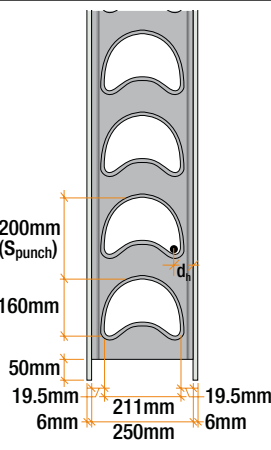
D5.1. Limited Ductile Wall Detailing

Standard AFS Wall Detailing for Limited Ductile Wall Designs in accordance with AS3600-2018 Section 2.2 and Clauses in 14.4 and 14.6. All limited Ductile Walls will have 2 Layers of reinforcement.

In general Wall fitments are not used in AFS Walls when designed in accordance to AS3600-2018 Clause 14.6 with $f'_c \leq 50$ MPa. If fitments are required in small areas outside of boundary elements consult the AFS Technical Support for assistance.

Boundary Elements

AS3600-2018 Cl14.6.2 Boundary Elements requires Boundary Elements where extreme fibre compressive stress exceeds $0.15 f'_c$. The extent and detailing of the boundary elements are to be determined by the designer.

requirements and are only to be installed by AFS approved experienced installers. AFS detailing is to be used unless AFS Technical Support reviews and approves alternate detailing.

AFS Boundary Elements have special installation

Reinforcement

In accordance with AS3600-2018 Cl14.6.7 maximum vertical reinforcement for AFS Logicwall® shall be 2.1% ($\text{Half } 21/f_{sy}$) including areas with boundary

elements and laps. Minimum horizontal and vertical reinforcement shall be 0.0025.

Structures not more the four stories

“For structures not more than four stories above their structural base and where boundary elements are required” [AS3600 Cl14.6.2.2] the AFS standard end detail may be used as the boundary element.

AFS Standard Boundary Element will be used at all Boundaries unless specified in the Project Documentation.

Fig D23: AFS Standard Boundary Element

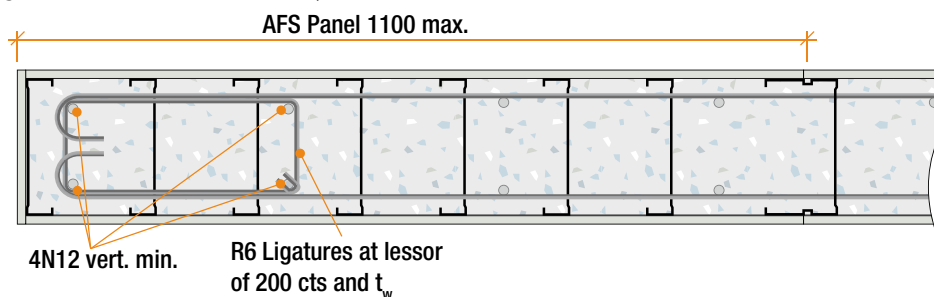

Structures more than four stories

For structures more than four stories CI14.6.2.3 requires boundary elements to conform to CI10.7.4. The AFS Standard Boundary Element below can be installed during installation of the walls.

Fig D24: AFS Standard Boundary Element

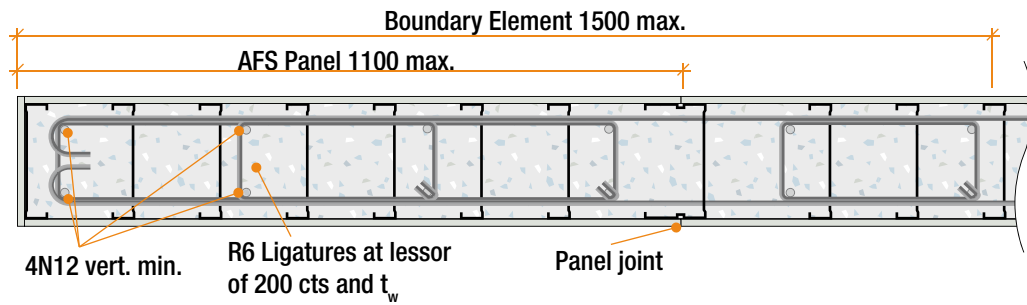

Boundary elements closed fitments are to be spaced vertically in accordance with Cl 14.6.2 of AS3600-2018 as follows:

- Spaced at lesser of t_w and 200mm
- For structures more than four stories as per Cl 14.6.2.3 of AS3600-2018.

Fig D25: AFS Limited Ductile Core Wall Detailing

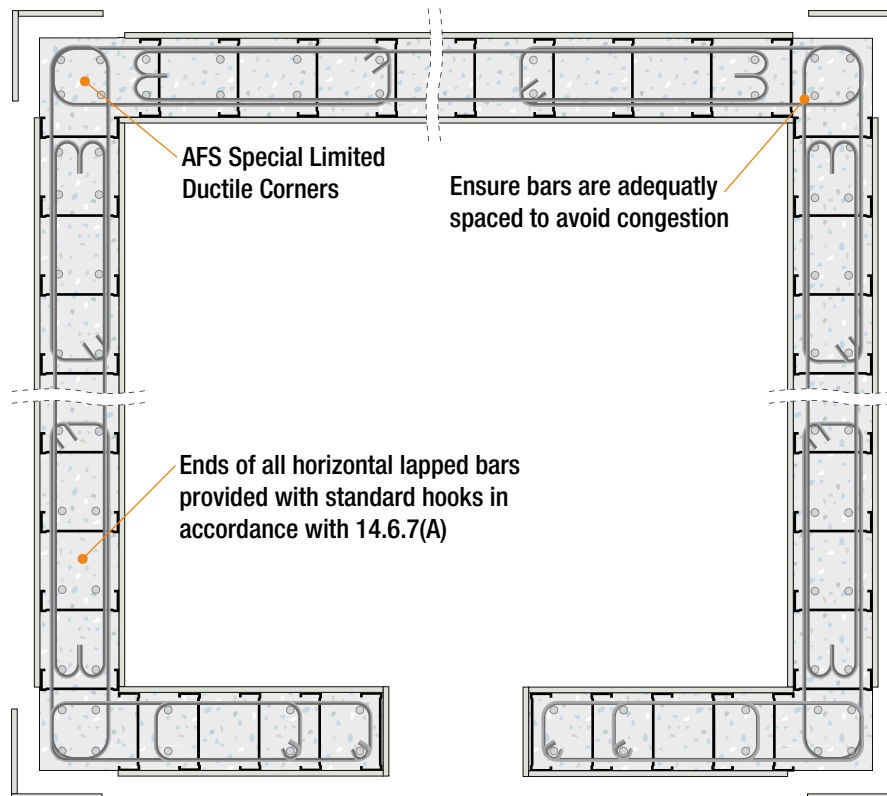

AFS Limited Ductile Wall Horizontal Reinforcement Wall Laps

AFS recommends Fig 14.6.7(D) of AS3600-2018 only be used where required. Alternatives to the 14.6.7 detail are:

- Construction joints to split the walls and prevent transfer of in-plane lateral and shear loads.

Fig D26: 14.6.7(D) Horizontal Wall Bar Lap Detail

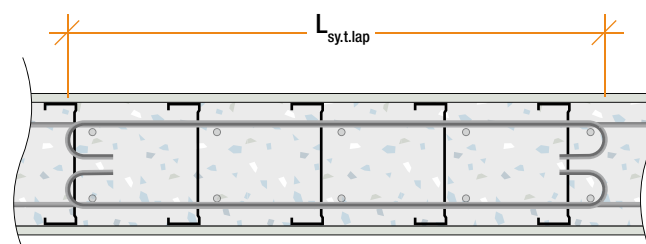

Blade Columns

Blade Columns

Are short wall designed as columns with ligatures to AS3600-2018 Sections 14 and 10.

Fig D27: Logicwall® Blade Column

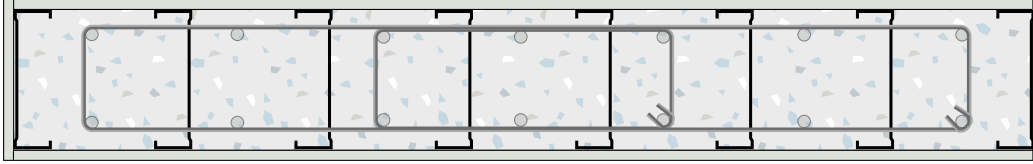

Junctions

AFS Standard Junctions

Standard Junctions are not to be used with Limited Ductile Walls. Junction Joints may be used to structurally isolate walls either side of the junction and prevent transfer of in-plane forces

AFS Special Junctions

Structural Documentation is to specify where Special Junctions are to be used. If detailing is required beyond these special junctions AFS Technical Support is to be consulted and detailing reviewed.

Special limited Ductile Junction Details –Without Boundary Elements

Fig D28: Corner Type 1

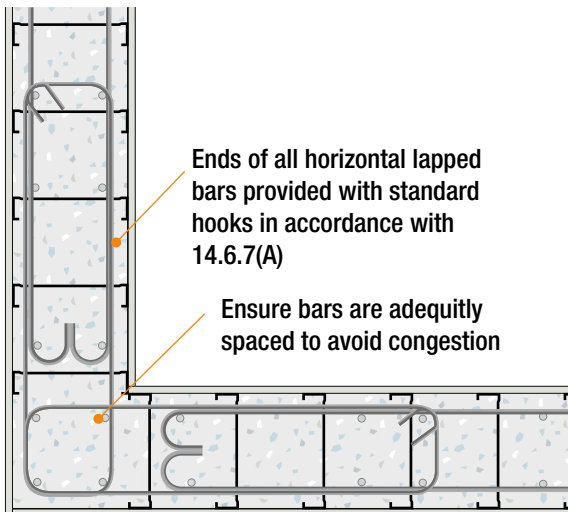
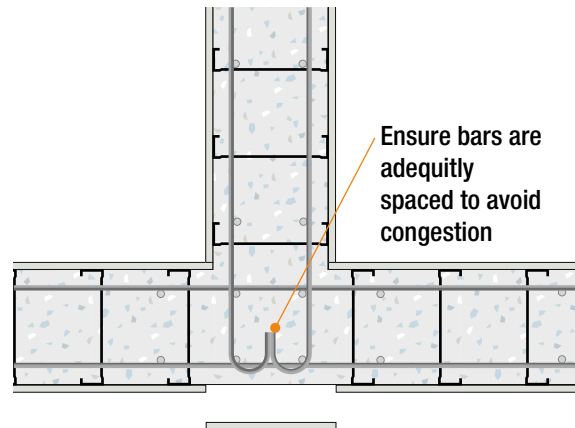

Fig D29: T junction



Movement Joints

Movement Joints will be required over any building joints and where specified on the Project Documentation

The structural concrete wall effectively has control joints at each stud so no additional crack control joints are necessary. Full depth "movement joints" may be required depending on the geometry of the structure and other considerations such as thermal loads, exposure and building joints. In general "movement

joints" would not be required for walls less than 16m long. Structural movement joints will be placed in locations nominated by the structural engineer and must be documented on structural drawings. These will be installed at construction stage by the AFS Logicwall® installation contractor.

The following method is recommended.

Fig D30: Logicwall® Movement joint

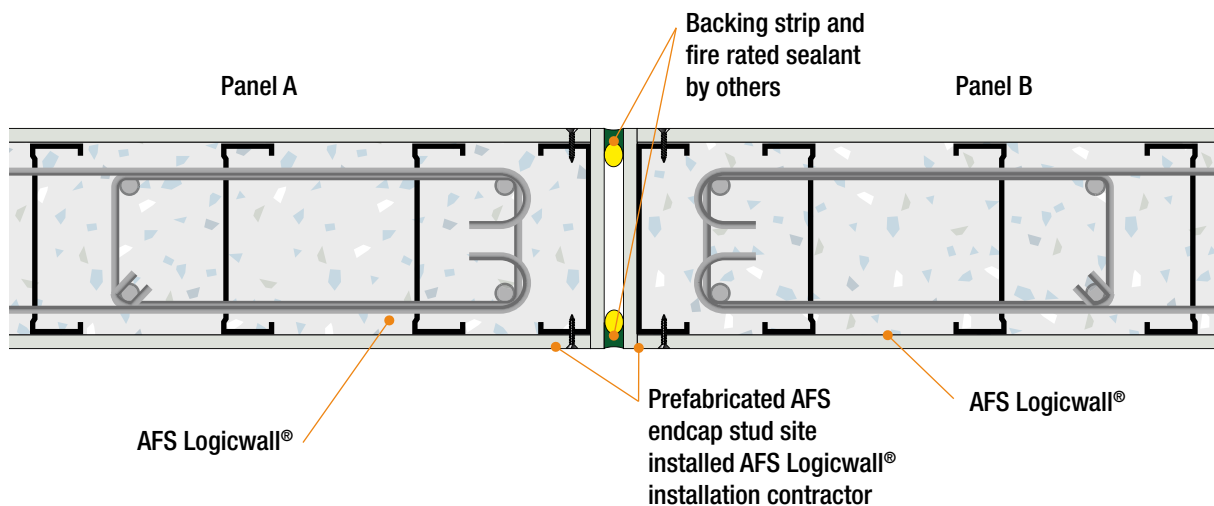

Note: Can be dowel jointed if required structurally. Must be clearly specified and negotiated with installers at time of tender. Installed where nominated by project engineer. Must be clearly documented on drawings. Typically not required in walls less than 16m in length.

Construction Joint

Construction Joints can be used wherever a pour break is required, walls may be split to prevent transfer of in-plane forces. Locations are to be specified on the Project Documentation.

Fig D32: Logicwall® Sheet Surface Joint

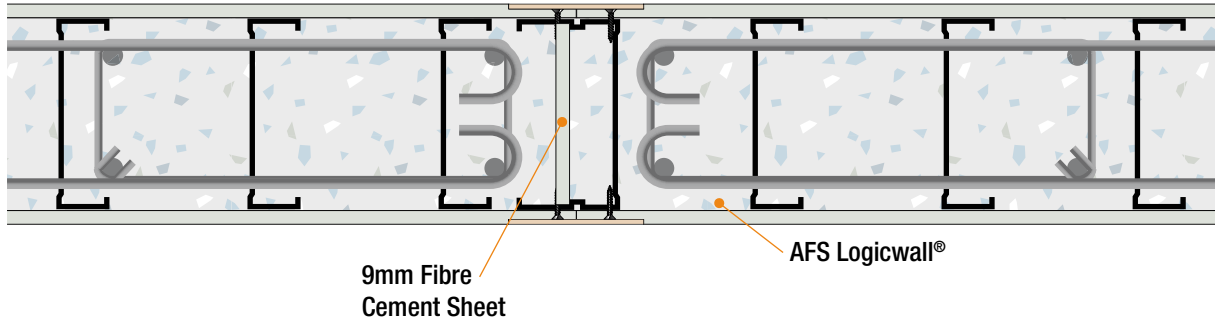

Wall Junctions Joints

Junction Joints to structurally isolate walls either side of the junction and prevent transfer of inplane forces.

Fig D33: Logicwall® Corner Joint

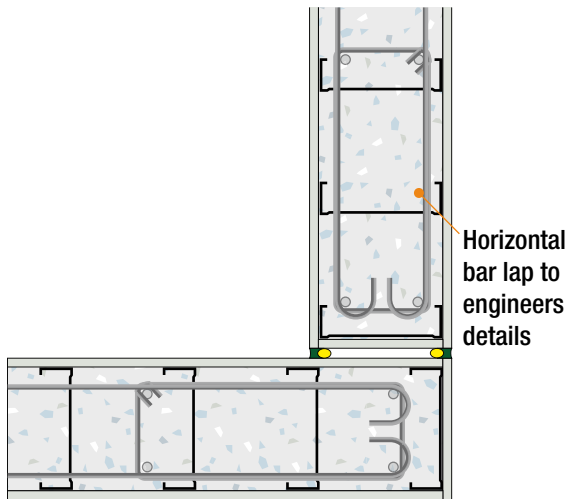
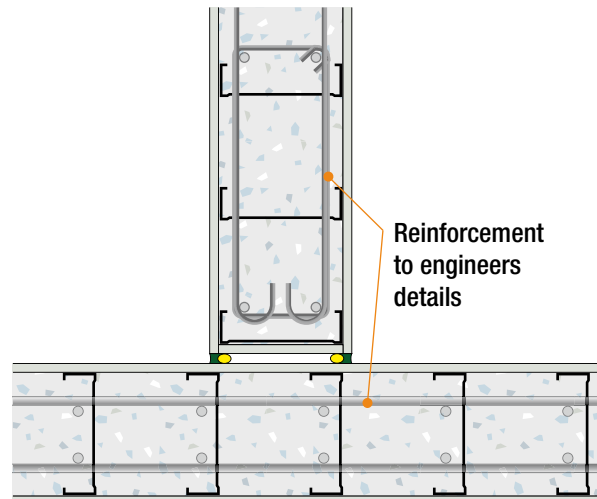

Fig D34: Logicwall® T joint



D6. CORE FILLING OF WALLS

Introduction

AFS Logicwall® cannot be filled with concrete using traditional concrete mixes. The concrete mix and concrete placement technique is critical to the successful outcome of filling rediwall®.

AFS has carried out tests which achieved desired compaction and dense, homogeneous coverage of afs rediwall®.

This guide sets out the methods used by AFS to achieve suitable compaction.

Use of this guide or an equivalent procedure to achieve compaction of Logicwall® is entirely at the discretion of the contractor or installer.

The contractor or installer is responsible for achieving compaction and dense, homogeneous coverage of the concrete mix in Logicwall®. AFS accepts no responsibility for achieving compaction of the concrete in AFS Logicwall® or core filling of walls.

Concrete Pour Limitations

When panel installation is complete and all appropriate bracing and checks completed, the walls can be filled with concrete.

The quantity of concrete that can be poured in a day must be assessed and determined in consideration of the following factors:

- Ease of access
- Number of passes (or lifts) that are required
- Concrete gelling time between passes
- Consideration of wet weather

For wet weather, on-site conditions should be assessed and the concrete pour either be delayed or be undertaken with caution, applying measures to suit the given conditions.

Additional Equipment Required for Concrete Pour

Prior to commencing a pour, ensure that a concrete vibrator with flexible shaft and 38mm head is ready for use, and that multiple shovels, trowels, screw guns, screws and at least one wheelbarrow are readily available.

AFS and Natspec

Natspec is a not-for-profit organisation that is owned by the design, build, construct and property industry through professional associations and government property groups. Natspec's major service is the comprehensive national specification system endorsed by government and professional bodies. The specification is for all building structures with specialist packages for architects, interior designers, landscape architects, structural, mechanical, hydraulic and electrical engineers and domestic owners.

The foundation of the Natspec specification system is the 'worksection'. Natspec worksections are selected and customized by the specifier to produce a project specification. In some instances, the specifier can choose between a generic worksection and a branded worksection when compiling the specification.

A Natspec branded worksection is developed by Natspec in conjunction with the manufacturer, known as a Natspec Product Partner. AFS has worked extensively with Natspec to become a product partner and to form the 'AFS Logicwall® In Concrete Combined' branded worksection.

This AFS Logicwall® product specific worksection/specification can be accessed via a link on the AFS website – www.AFSwall.com.au or by going directly to the Natspec website – www.natspec.com.au and has been formulated so that project designers/specifiers can produce a project specific specification for either:

1. AFS Logicwall® combined with all concrete works on the project, OR
2. AFS Logicwall® component of the project only.

